



Siemens Airfield Solutions F-Range High Intensity Style 2 Approach Light FAA-E-2491, FAA-E-2952 and FAA-E-2968

Document No. 96A0293

Issued: February 21, 2005

Rev. C: March 8, 2005

Siemens Airfield Solutions, Inc.

P.O. Box 30829
977 Gahanna Parkway
Columbus, OH 43230

Tel: (614) 861-1304
Fax: (614) 864-2069

Copyright © 2005 by Siemens Airfield Solutions, Incorporated. All rights reserved.

Siemens Airfield Solutions

*The innovative
approach*

Record of Changes

Page	Rev	Description	EC No.	Checked	Approved	Date
	A	Released manual.	00829	JY	WT	2/21/02
As Needed	B	Added MALSR info	01392	WT	WT	2/25/05
7-3, 7-8	C	44A6151-10 was 6141-10	01393	WT	WT	3/8/05

Table of Contents

Record of Changesii
 Table of Contentsiii
 Warrantiesvi

Safety

Section 1 Safety..... 1-1
 1. Introduction 1-1
 2. Safety Symbols 1-1
 3. Qualified Personnel 1-2
 4. Intended Use 1-2
 5. Installation 1-3
 6. Operation 1-4
 7. Action in the Event of a System or Component Malfunction..... 1-4
 8. Maintenance and Repair 1-4

Description

Section 2 Description 2-1
 1. Introduction 2-1
 2. Optical Unit 2-3
 3. Inner Pan Subassembly 2-4
 4. Lamp and Filter Holder Assembly 2-5
 5. Lamp Shorting Device..... 2-5
 6. F-Range High Intensity Style 2 Approach Light: Required
 Equipment 2-5
 7. Specifications 2-5
 Lamps 2-5
 Isolation Transformers 2-6
 Rated Lamp Life 2-6
 Lens Colors 2-6
 Light Beam 2-6
 Mounting 2-6
 Environmental Operating Conditions..... 2-6
 Dimensions 2-6
 Weight 2-7

Installation

Section 3 Installation 3-1
 1. Introduction 3-1
 2. Unpacking 3-1
 3. Input Requirement Summary 3-1
 4. F-Range Light Fixtures Not Toed..... 3-1
 5. Installation on L-868B Base 3-2
 6. Installation in Existing LB-4 Light Bases 3-4

Maintenance

Section 4 Maintenance 4-1

1. Introduction 4-1

2. Maintenance Schedule 4-1

3. Maintenance Procedures..... 4-2

 Replacing Lamp 4-2

 Cleaning Light Channel and Prism 4-2

 Retorquing Mounting Bolts 4-3

 Removing L-868 Base Water 4-4

 Lifting Optical Unit Out of Base 4-4

 Testing for Leaks..... 4-5

Troubleshooting

Section 5 Troubleshooting 5-1

1. Introduction 5-1

2. Troubleshooting Procedures 5-2

Repair

Section 6 Repair 6-1

1. Introduction 6-1

2. Opening Optical Unit 6-1

3. Replacing Lamp and Filter 6-3

4. Replacing Prism 6-7

5. Replacing Optical Unit..... 6-10

6. Replacing L-823 Cordset 6-12

7. Closing Optical Unit 6-15

Parts

Section 7 Parts..... 7-1

1. Introduction 7-1

2. Using the Illustrated Parts List 7-1

3. F-Range High Intensity Style 2 Approach Light
 Part Numbering System..... 7-2

4. F-Range High Intensity Style 2 Approach Light Parts List 7-3

5. F-Range Optical Unit Parts List..... 7-7

6. Recommended Spare Parts..... 7-8

List of Figures

Figure 2-1 Top View of F-Range High Intensity Style 2 Approach Light	2-1
Figure 2-2 Cutaway View of F-Range High Intensity Style 2 Approach Light	2-2
Figure 2-3 F-Range High Intensity Style 2 Optical Unit	2-3
Figure 2-4 Inner Pan Subassembly	2-4
Figure 3-1 Installation on L-868B Light Base	3-2
Figure 3-2 Existing 20 A, 500 W Fixture in LB-4 Can	3-4
Figure 3-3 Existing 20 A, 500 W Fixture and Transformer Removed from LB-4 Can	3-5
Figure 3-4 New Transformer Substituted	3-5
Figure 3-5 Add New Adapter Ring and Light Fixture	3-6
Figure 4-1 Sequence for Torquing Mounting Bolts	4-3
Figure 4-2 Pressure Release Screw	4-5
Figure 4-3 Pressure Test Fitting Assembly	4-5
Figure 6-1 Pressure Release Screw	6-1
Figure 6-2 Removing Screws	6-2
Figure 6-3 Separating Inner Cover from Top Cover	6-2
Figure 6-4 Red or Green Optical Support Assembly	6-4
Figure 6-5 White Optical Support Assembly	6-5
Figure 6-6 Arrow Pointing Up	6-6
Figure 6-7 Replacing Prism	6-8
Figure 6-8 Flat Seal for Prism	6-9
Figure 6-9 Sock Seal for Prism	6-9
Figure 6-10 Removing Optical Unit from Inner Pan Assembly	6-11
Figure 6-11 L-823 Cordset	6-13
Figure 6-12 Fast-On Connectors	6-14
Figure 6-13 F-Range High Intensity Style 2 Approach Light Fixture	6-16
Figure 7-1 F-Range High Intensity Style 2 Approach Light Part Number	7-2
Figure 7-2 F-Range High Intensity Style 2 Approach Light (1 of 3)	7-5

List of Tables

Table 2-1 Required Equipment Supplied	2-5
Table 2-2 Required Equipment Not Supplied	2-5
Table 2-3 Required Isolation Transformers	2-6
Table 4-1 F-Range Light Fixture Maintenance	4-1
Table 6-1 Parts List for Replacing Lamp and Filter	6-3
Table 6-2 Parts List for Replacing Prism	6-7
Table 6-3 Parts List for Replacing Optical Unit	6-10
Table 6-4 Parts List for Replacing L-823 Cordset	6-12
Table 6-5 Parts List for Closing Optical Unit	6-15

Warranties

Products of Siemens Airfield Solutions manufacture are guaranteed against mechanical, electrical, and physical defects (excluding lamps) for a period of one year from the date of installation or a maximum of two years from the date of shipment and are guaranteed to be merchantable and fit for the ordinary purposes for which such products are made.

Siemens Airfield Solutions will correct by repair or replacement, at its option, equipment or parts which fail because of mechanical, electrical or physical defects, provided that the goods have been properly handled and stored prior to installation, properly installed and properly operated after installation, and provided further that Buyer gives Siemens Airfield Solutions written notice of such defects after delivery of the goods to Buyer.

Siemens Airfield Solutions reserves the right to examine goods upon which a claim is made. Said goods must be presented in the same condition as when the defect therein was discovered. Siemens Airfield Solutions further reserves the right to require the return of such goods to establish any claim.

Siemens Airfield Solutions's obligation under this guarantee is limited to making repair or replacement within a reasonable time after receipt of such written notice and does not include any other costs such as the cost of removal of defective part, installation of repaired product, labor or consequential damages of any kind, the exclusive remedy being to require such new parts to be furnished.

Siemens Airfield Solutions's liability under no circumstances will exceed the contract price of goods claimed to be defective. Any returns under this guarantee are to be on a transportation charges prepaid basis. For products not manufactured by, but sold by Siemens Airfield Solutions, warranty is limited to that extended by the original manufacturer.

This is Siemens Airfield Solutions's sole guarantee and warranty with respect to the goods; there are no express warranties or warranties of fitness for any particular purpose or any implied warranties of fitness for any particular purpose or any implied warranties other than those made expressly herein. All such warranties being expressly disclaimed.

Disclaimers

This manual could contain technical inaccuracies or typographical errors. Siemens Airfield Solutions reserves the right to revise this manual from time to time in the contents thereof without obligation of Siemens Airfield Solutions to notify any person of such revision or change.

Details and values given in this manual are average values and have been compiled with care. They are not binding, however, and Siemens Airfield Solutions disclaims any liability for damages or detriments suffered as a result of reliance on the information given herein or the use of products, processes or equipment to which this manual refers. No warranty is made that the use of the information or of the products, processes or equipment to which this manual refers will not infringe any third party's patents or rights. The information given does not release the buyer from making their own experiments and tests.

Section 1

Safety

1. Introduction

This section contains general safety instructions for using your Siemens Airfield Solutions equipment. Some safety instructions may not apply to the equipment in this manual. Task- and equipment-specific warnings are included in other sections of this manual where appropriate. Note all warnings and follow all instructions carefully. Failure to do so may result in personal injury, death, or property damage.

To use this equipment safely,

- refer to the FAA Advisory Circular AC 150/5340-26, *Maintenance of Airport Visual Aids Facilities*, for instructions on safety precautions.
- observe all safety regulations. To avoid injuries, always remove power prior to making any wire connections and touching any parts. Refer to FAA Advisory Circular AC 150/5340-26.
- read and become familiar with the general safety instructions provided in this section of the manual before installing, operating, maintaining, or repairing this equipment.
- read and carefully follow the instructions given throughout this manual for performing specific tasks and working with specific equipment.
- store this manual within easy reach of personnel installing, operating, maintaining, or repairing this equipment.
- follow all applicable safety procedures required by your company, industry standards, and government or other regulatory agencies.
- obtain and read Material Safety Data Sheets (MSDS) for all materials used.

2. Safety Symbols

Become familiar with the safety symbols presented in this section. These symbols will alert you to safety hazards and conditions that may result in personal injury, death, or property and equipment damage.



WARNING: Failure to observe this warning may result in personal injury, death, or equipment damage.

2. Safety Symbols (contd.)



WARNING: Risk of electrical shock. Failure to observe this warning may result in personal injury, death, or equipment damage.



WARNING: Disconnect equipment from line voltage. Failure to observe this warning may result in personal injury, death, or equipment damage.



WARNING: Wear safety goggles. Failure to observe may result in serious injury.



CAUTION: Failure to observe may result in equipment damage.

3. Qualified Personnel

The term *qualified personnel* is defined here as individuals who thoroughly understand the equipment and its safe operation, maintenance, and repair. Qualified personnel are physically capable of performing the required tasks, familiar with all relevant safety rules and regulations and have been trained to safely install, operate, maintain, and repair the equipment. It is the responsibility of the company operating this equipment to see that its personnel meet these requirements.

4. Intended Use



WARNING: Use of this equipment in ways other than described in this manual may result in personal injury, death, or property and equipment damage. Use this equipment only as described in this manual.

Siemens Airfield Solutions cannot be responsible for injuries or damages resulting from nonstandard, unintended applications of its equipment. This equipment is designed and intended only for the purpose described in this manual. Uses not described in this manual are considered unintended uses and may result in serious personal injury, death, or property damage. Unintended uses may result from taking the following actions:

- making changes to equipment that have not been recommended or described in this manual or using parts that are not genuine Siemens Airfield Solutions replacement parts
- failing to make sure that auxiliary equipment complies with approval agency requirements, local codes, and all applicable safety standards

4. Intended Use *(contd.)*

- using materials or auxiliary equipment that are inappropriate or incompatible with your Siemens Airfield Solutions equipment
- allowing unqualified personnel to perform any task

5. Installation

Read the installation section of all system component manuals before installing your equipment. A thorough understanding of system components and their requirements will help you install the system safely and efficiently.



WARNING: Failure to follow these safety procedures can result in personal injury or death.

- Allow only qualified personnel to install Siemens Airfield Solutions and auxiliary equipment. Use only approved equipment. Using unapproved equipment in an approved system may void agency approvals.
- Make sure all equipment is rated and approved for the environment in which you are using it.
- Follow all instructions for installing components and accessories.
- Install all electrical connections to local code.
- Use only electrical wire of sufficient gauge and insulation to handle the rated current demand. All wiring must meet local codes.
- Route electrical wiring along a protected path. Make sure they will not be damaged by moving equipment.
- Protect components from damage, wear, and harsh environment conditions.
- Allow ample room for maintenance, panel accessibility, and cover removal.
- Protect equipment with safety devices as specified by applicable safety regulations.
- If safety devices must be removed for installation, install them immediately after the work is completed and check them for proper functioning.

6. Operation

Only qualified personnel, physically capable of operating the equipment and with no impairments in their judgment or reaction times, should operate this equipment.

Read all system component manuals before operating this equipment. A thorough understanding of system components and their operation will help you operate the system safely and efficiently.

- Before starting this equipment, check all safety interlocks, fire-detection systems, and protective devices such as panels and covers. Make sure all devices are fully functional. Do not operate the system if these devices are not working properly. Do not deactivate or bypass automatic safety interlocks or locked-out electrical disconnects or pneumatic valves.
- Never operate equipment with a known malfunction.
- Do not attempt to operate or service electrical equipment if standing water is present.
- Use this equipment only in the environments for which it is rated. Do not operate this equipment in humid, flammable, or explosive environments unless it has been rated for safe operation in these environments.
- Never touch exposed electrical connections on equipment while the power is ON.

7. Action in the Event of a System or Component Malfunction

Do not operate a system that contains malfunctioning components. If a component malfunctions, turn the system OFF immediately.

- Disconnect and lock out electrical power.
- Allow only qualified personnel to make repairs. Repair or replace the malfunctioning component according to instructions provided in its manual.

8. Maintenance and Repair

Allow only qualified personnel to perform maintenance, troubleshooting, and repair tasks. Only persons who are properly trained and familiar with Siemens Airfield Solutions equipment are permitted to service this equipment.

- Always use safety devices when working on this equipment.
- Follow the recommended maintenance procedures in your equipment manuals.
- Do not service or adjust any equipment unless another person trained in first aid and CPR is present.

8. Maintenance and Repair
(*contd.*)

- Connect all disconnected equipment ground cables and wires after servicing equipment. Ground all conductive equipment.
- Use only approved Siemens Airfield Solutions replacement parts. Using unapproved parts or making unapproved modifications to equipment may void agency approvals and create safety hazards.
- Check interlock systems periodically to ensure their effectiveness.
- Do not attempt to service electrical equipment if standing water is present. Use caution when servicing electrical equipment in a high-humidity environment.
- Use tools with insulated handles when working with electrical equipment.

Section 2 Description

1. Introduction

This section describes the Siemens Airfield Solutions F-Range high intensity Style 2 approach light.

See Figures 2-1 and 2-2. The F-Range high intensity Style 2 approach light marks the centerline, crossbar, and side row barrettes. It is manufactured in accordance with FAA specification FAA-E-2491 (to be superseded by FAA-E-2952) and to FAA-E-2968 (≤ 0.50 inches height above grade). The fixture is supplied with either no filters (white), or 3 red filters, or 3 green filters.

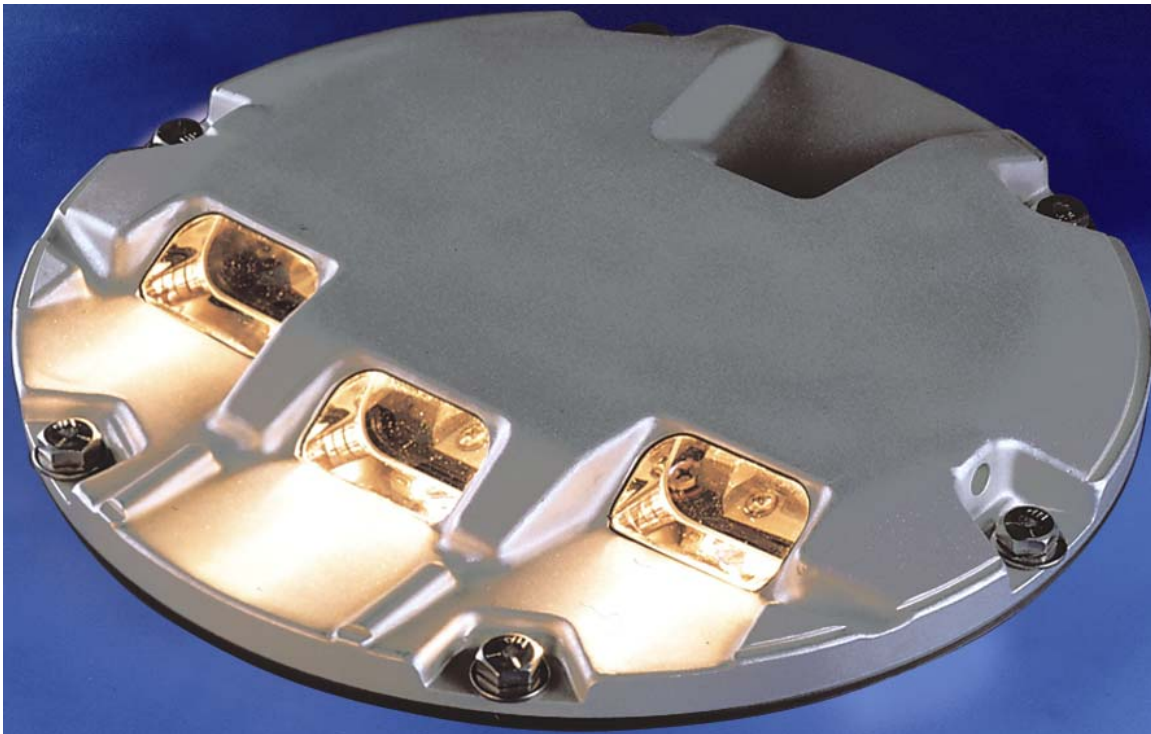

Figure 2-1 Top View of F-Range High Intensity Style 2 Approach Light

1. Introduction (contd.)

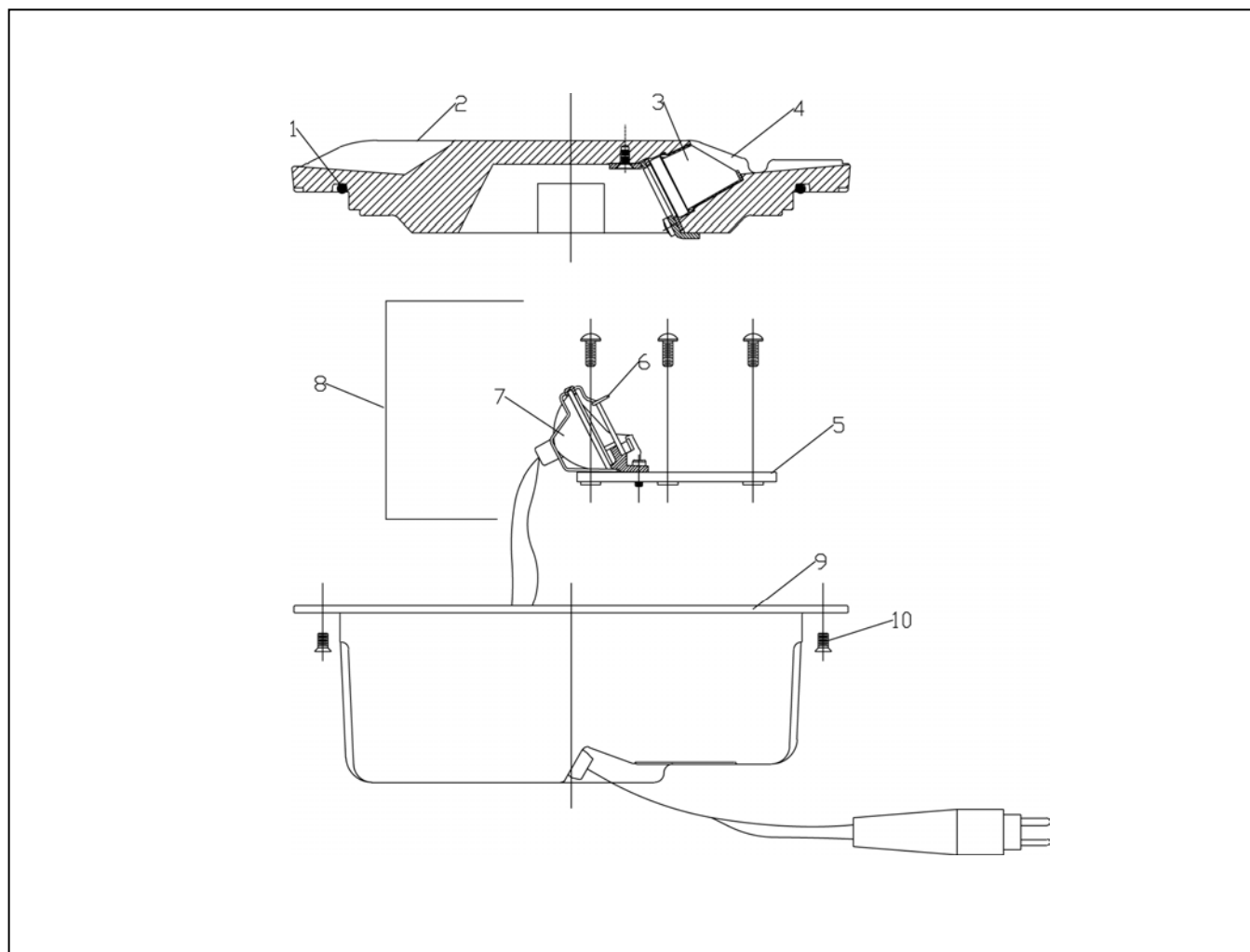

Figure 2-2 Cutaway View of F-Range High Intensity Style 2 Approach Light

- | | | | |
|--------------|-----------------------------|-----------------|------------------------------|
| 1. O-Ring | 4. Light Channel | 7. Lamp | 10. Phillips Flat Head Screw |
| 2. Top Cover | 5. Optical Support Assembly | 8. Optical Unit | |
| 3. Prism | 6. Lamp Holder Assembly | 9. Inner Cover | |

2. Optical Unit

See Figure 2-3 for the optical unit. The F-Range series light fixture optical unit consists of three unidirectional 105 W/MR16 lamps, prisms, and color filters.

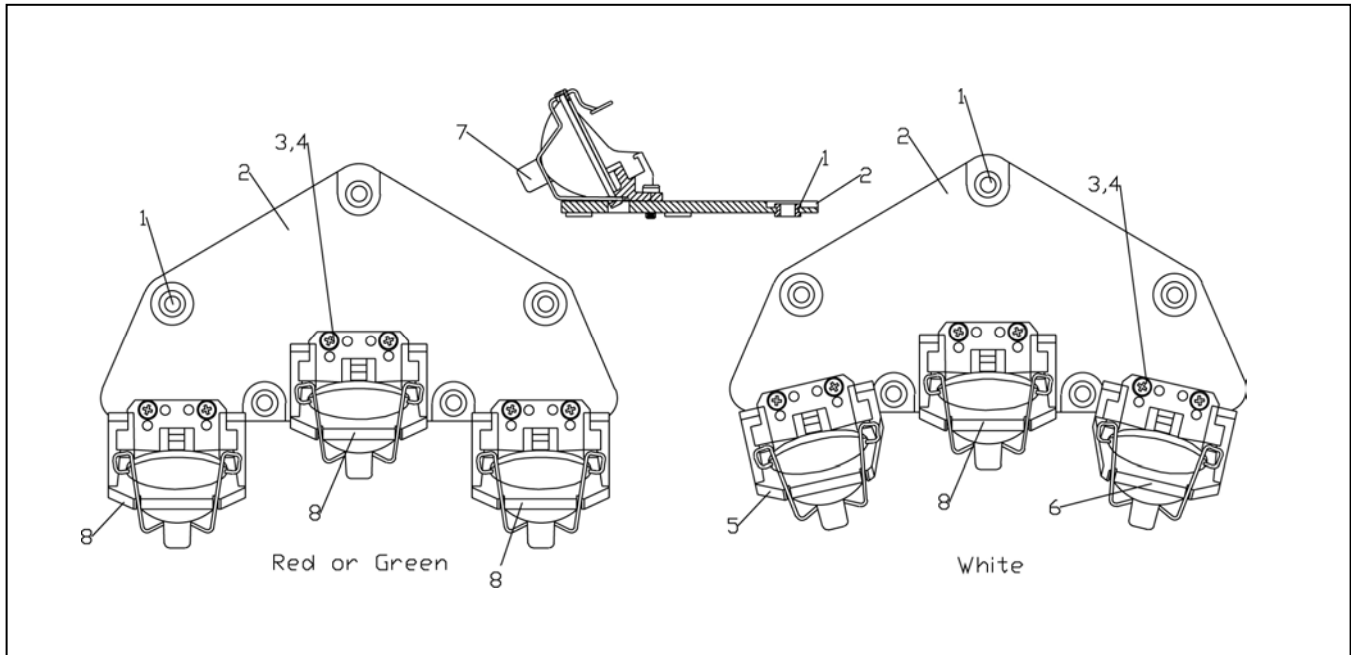

Figure 2-3 F-Range High Intensity Style 2 Optical Unit

- | | | |
|--------------------|--|-------------------------|
| 1. Grommet | 4. Lockwasher | 7. Lamp |
| 2. Optical Bracket | 5. Modified Lamp Holder Assembly, Left-Hand | 8. Lamp Holder Assembly |
| 3. Screw | 6. Modified Lamp Holder Assembly, Right-Hand | |

3. Inner Pan Subassembly

See Figure 2-4. The inner pan subassembly is comprised of the inner cover (6), L-823 cordset (10), terminal block(s) (without film disc cutout) (1), fast-on connectors (2), O-ring (5), wire clamp (8), screw (9), and pressure release screw (4).

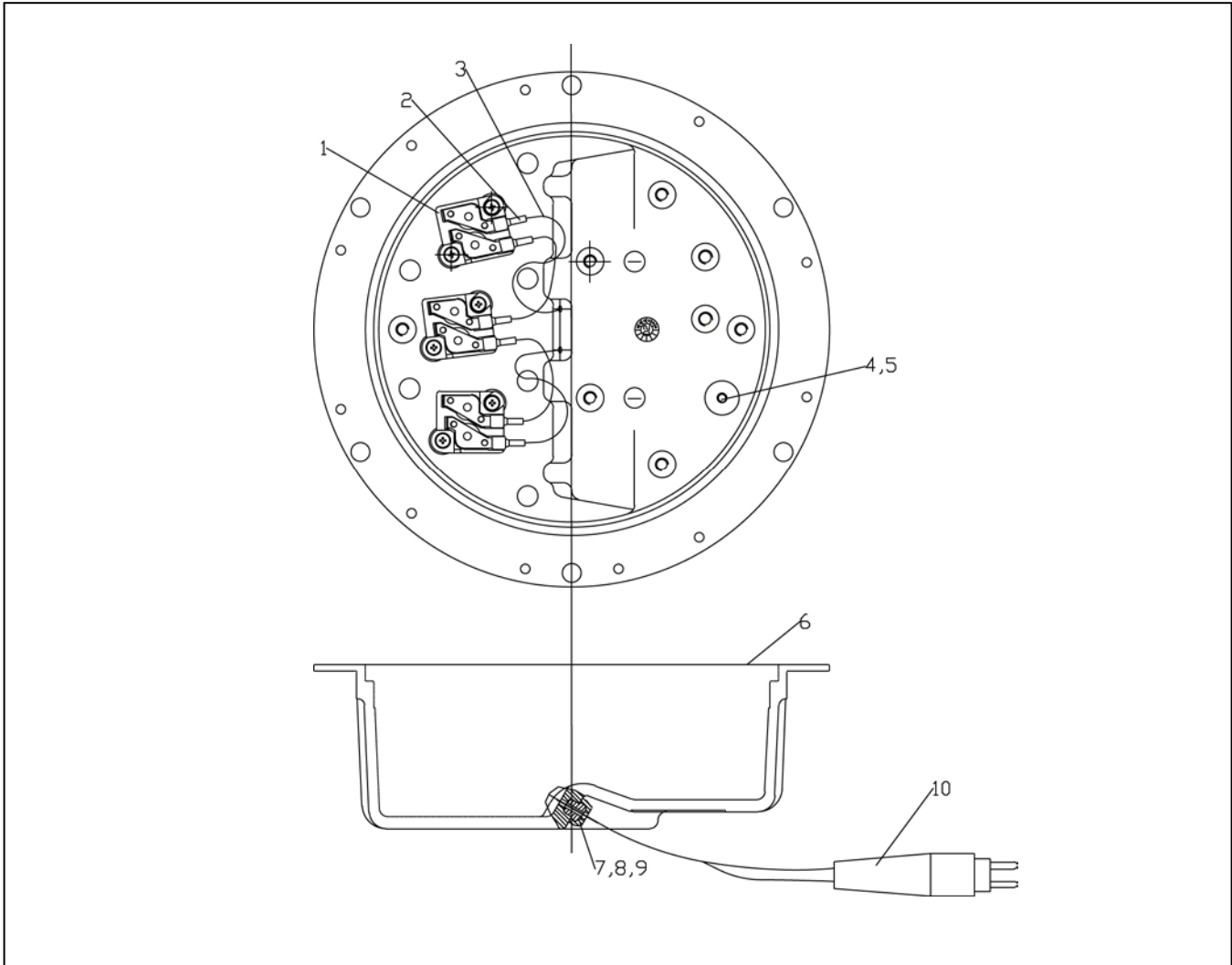

Figure 2-4 Inner Pan Subassembly

- | | | | |
|-----------------------|---------------------------|------------------|-------------|
| 1. Terminal Blocks | 4. Pressure Release Screw | 7. Wire Grommets | 10. Cordset |
| 2. Fast-On Connectors | 5. O-Ring | 8. Wire Clamp | |
| 3. Cable Assembly | 6. Inner Cover | 9. Screw | |

4. Lamp and Filter Holder Assembly

See Figure 2-2. The lamp and filter holder assembly (6) consists of the lamp/filter support subassembly, lamp clip, screws, and washers. The lamp/filter support subassembly is pre-assembled at the factory.

5. Lamp Shorting Device

An optional lamp shorting device is available as an electrical bypass device in case of lamp failure. It closes an auxiliary circuit around the lamp within 15 seconds after lamp failure. The lamp shorting device shorts and completes the circuit when the lamp fails. This allows the other lamps to remain lighted in series-connected fixtures. It also prevents excessive volt amperes on the secondary of the isolation transformer.

6. F-Range High Intensity Style 2 Approach Light: Required Equipment

Refer to Table 2-1 for required equipment that is supplied. Refer to Table 2-2 for required equipment that is not supplied. Refer to the *Parts* section for part numbers.

Table 2-1 Required Equipment Supplied

Description	Quantity
F-Range high intensity Style 2 approach light	1
Instruction manual	1 per order

Table 2-2 Required Equipment Not Supplied

Description	Quantity
Torque wrench (0 to 200 in-lb) (0–22.6 Nt-M)	1
Alignment jig	1
Diamond-faced core drill, 13 in. (330 mm diameter)	1
Diamond-faced saw, 3/8 in. (9.525 mm) thick	1
Crimping tool	1
Small water suction pump	1
L-830 isolation transformer. Refer to Table 2-3 for required isolation transformers.	1
Eyebolt, 3/8 in. (9.525 mm) diameter	2
Lifting rod, 16 in. (406 mm) long	1
Set of fiber brushes	1
Set of socket wrenches, 1/2 in. (12.7 mm) drive	1
Set of screwdrivers, one with 3/8 in. (9.525 mm) minimum blade width	1
Silicone grease	As required
Joint sealing filler	As required

7. Specifications

This subsection provides specifications for the F-Range high intensity Style 2 approach light.

Lamps

Three 105 W lamps (total of 315 watts)

Isolation Transformers

Refer to Table 2-3.

Table 2-3 Required Isolation Transformers

Lamps	Series Circuit	Isolation Transformer	Watts	Amperes	Hz
105 W unidirectional	6.6 A	L-830	300	6.6/6.6	60
105 W unidirectional MALSR Application	Voltage Input 240Vac	Voltage Ratio 240Vac to 15.9Vac Part No. 35C0095	105	6.6A max Into lamps	60

Rated Lamp Life

1000 hours

Lens Colors

White, green, red

Light Beam

Unidirectional

Mounting

The F-Range light fixture mounts only to the L-868B light base. An L-823 cordset is also supplied.

The light fixture can also be mounted to an existing LB-4 can. Refer to *Installation in Existing LB-4 Light Bases* in Section 3, *Installation*.

Environmental Operating Conditions

The F-Range light fixture is designed to operate under the conditions presented below for temperature, altitude, and relative humidity.

Temperature

-55 to + 55 °C (-67 to +131 °F)

Altitude

Sea level to 10,000 feet (3000 m)

Relative Humidity

Up to 100 %

Dimensions

Refer below for the F-Range approach light dimensions in cardboard box.

13 x 13 x 7 inches (330 x 330 x 180 mm)

Weight

Weight of F-Range approach light is 17.7 lb (8.03 kg).

Section 3

Installation



WARNING: Allow only qualified personnel to perform the following tasks. Observe and follow the safety instructions in this document and all other related documentation.

1. Introduction

This section provides instructions for installing the F-Range approach lights. Refer to airport project plans and specifications for the specific installation instructions. The installation shall conform to the applicable sections of the National Electric Code and local codes.

2. Unpacking

Each unit is individually packaged in a durable, cushioned, corrugated cardboard carton. To avoid unnecessary damage to the light assembly, unpack the carton at the installation site.

To unpack the carton, open the flaps and carefully remove the top packing material. Thread an eyebolt into each of the two opposite threaded holes. Run a rod through the eyebolts and lift the light assembly from the shipping carton. Set the light assembly in a protected area.

If damage to any equipment is noted, file a claim form with the carrier immediately. The carrier may request to inspect the equipment.

3. Input Requirement Summary

The F-Range light fixture is designed for connection to a 6.6 A or 20 A series lighting circuit via an L-830 isolation transformer. Refer to *Specifications* in the *Description* section for required isolation transformers.

4. F-Range Light Fixtures Not Toed

See Figures 6-4 and 6-5 in Section 6, *Repairs*. All three light beams of the F-Range high intensity Style 2 approach light fixtures, whether red or green, are not toed. The white approach light beams have the two outer lamps toed at 13.5 degrees in opposite directions while the center light is not toed. Toeing of the light beam is not related to the location of the fixture in relationship to the runway centerline.

5. Installation on L-868B Base

The light assembly is shipped complete, including the lamp, and is ready for installation.

To install the F-Range light fixture on the L-868B base, perform the following procedure:

1. See Figure 3-2. Clean the base receptacle. Make sure that the base receptacle does not contain water and is completely clean and dry. The mating surfaces must be clean and free of foreign particles.

NOTE: When using an L-868B bottom section and top section, a minimum of 3-3/4-in. height must be used for the top section or the fixture will not fit. This dimension does not account for flange rings and/or spacers.

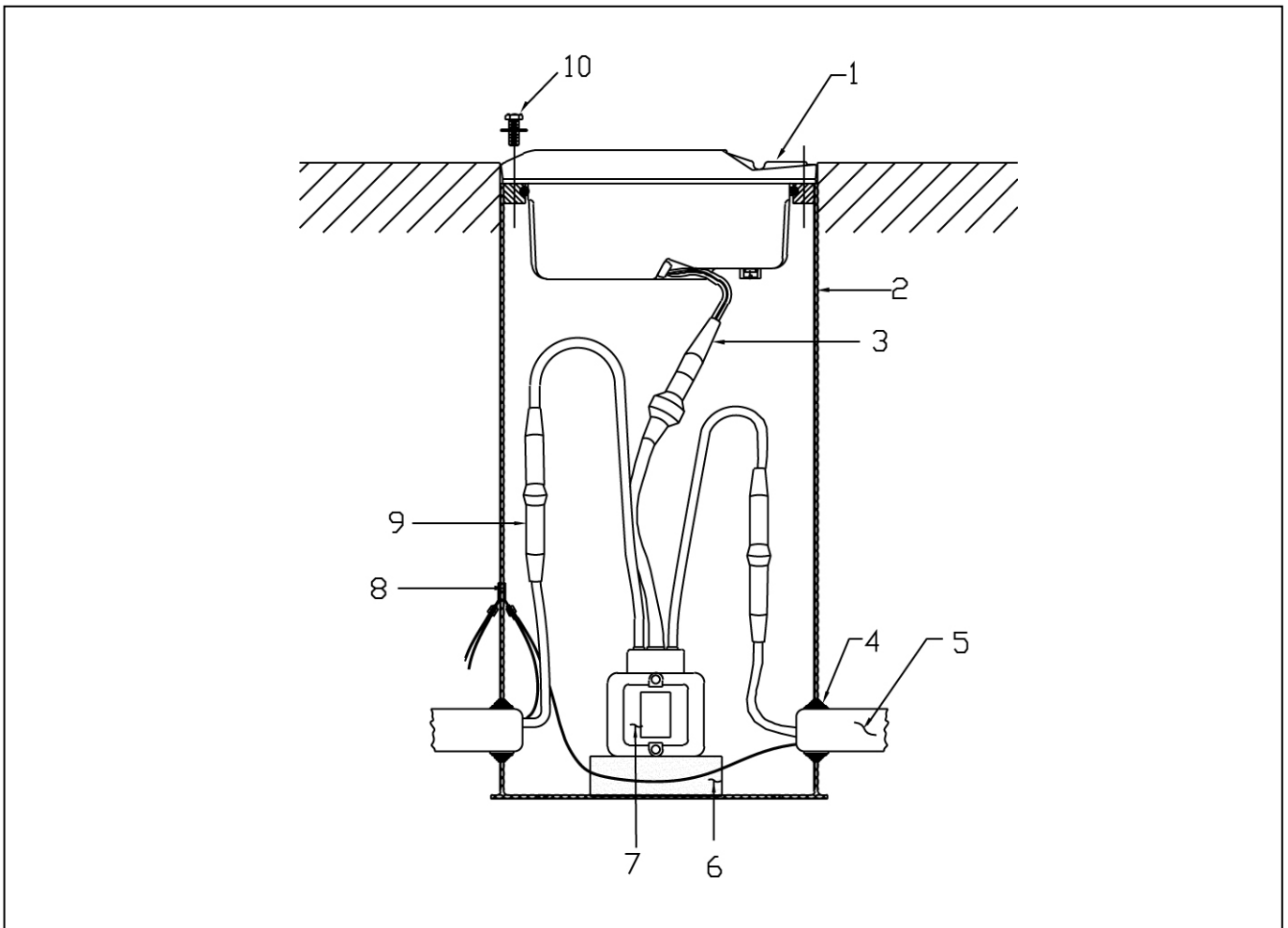

Figure 3-1 Installation on L-868B Light Base

- | | | | |
|-------------------------|-------------------|--------------------------|--------------------|
| 1. Light Fitting | 4. Rubber Grommet | 7. Isolation Transformer | 10. Screw, 3/8 in. |
| 2. L-868B Deep Base | 5. Conduit | 8. Ground Lug | |
| 3. Secondary Connectors | 6. Spacer | 9. Primary Connector | |

5. Installation on L-868B Base (contd.)

2. Slide a 16-inch- (406-mm-) long rod through the 3/8-inch- (9.525-mm-) diameter eyebolts and carry the light assembly to the base. Align the light assembly with the runway for proper light direction.
3. Place the light assembly beside the opening in the L-868B base so that the L-823 connector can be connected with the mating receptacle from the L-830 isolation transformer in the base. Make sure that the connection is solid and secure. Refer to *Specifications* in the *Description* section for required isolation transformers.
4. Turn on the power. Operate the light assembly for a minimum of five minutes. Turn off the power and allow the light assembly to cool.
5. Position the light assembly over the L-868B base and set onto the base. Align the light to the runway centerline. Make sure items such as spacers, shims, and gaskets are installed on the light base per site plans, specifications, and drawings. Remove the eyebolts and lifting rod.
6. Turn on the power to check that the lamp will illuminate. Operate for a minimum of five minutes.



CAUTION: The light assembly will be hot after this test. Allow time for assembly to cool before proceeding.

7. Apply one drop of Loctite AV to each of the six light assembly mounting bolts. Install the six bolts and lockwashers. Torque the bolts to 185 ±5 inch-pounds (20.902 ±0.565 Nt-M). Torque across the corners. Refer to *Retorquing Mounting Bolts* in the *Maintenance* section.

6. Installation in Existing LB-4 Light Bases

To install the F-Range high intensity Style 2 approach light in an existing LB-4 light base, perform the following procedure:

1. See Figure 3-2. Remove the old 20 A, 500 W, FAA-E-2491 light fixture.

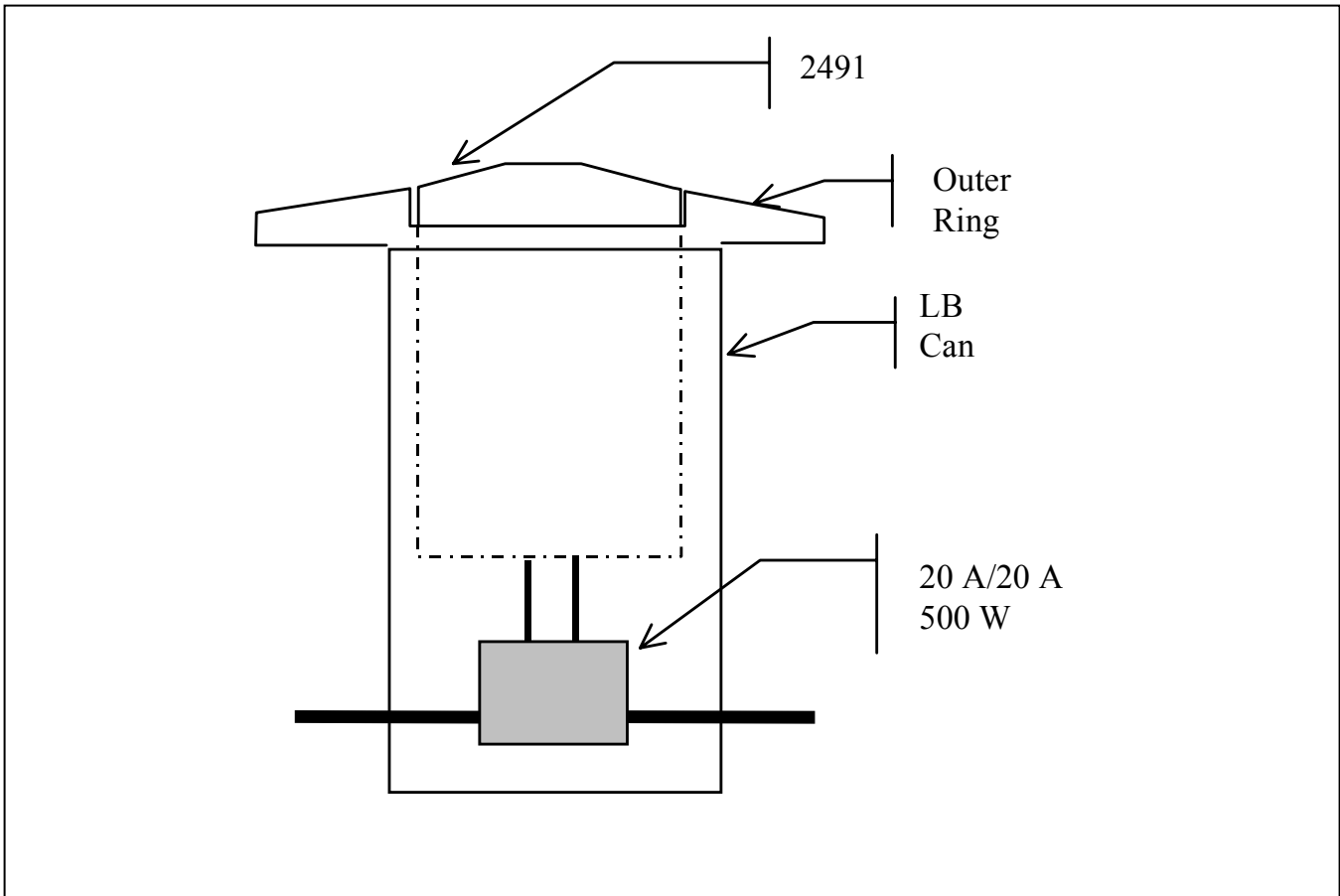

Figure 3-2 Existing 20 A, 500 W Fixture in LB-4 Can for 2491 Application

6. Installation in Existing LB-4 Light Bases *(contd.)*

- 2. See Figure 3-3. Remove the 20 A/20 A transformer.

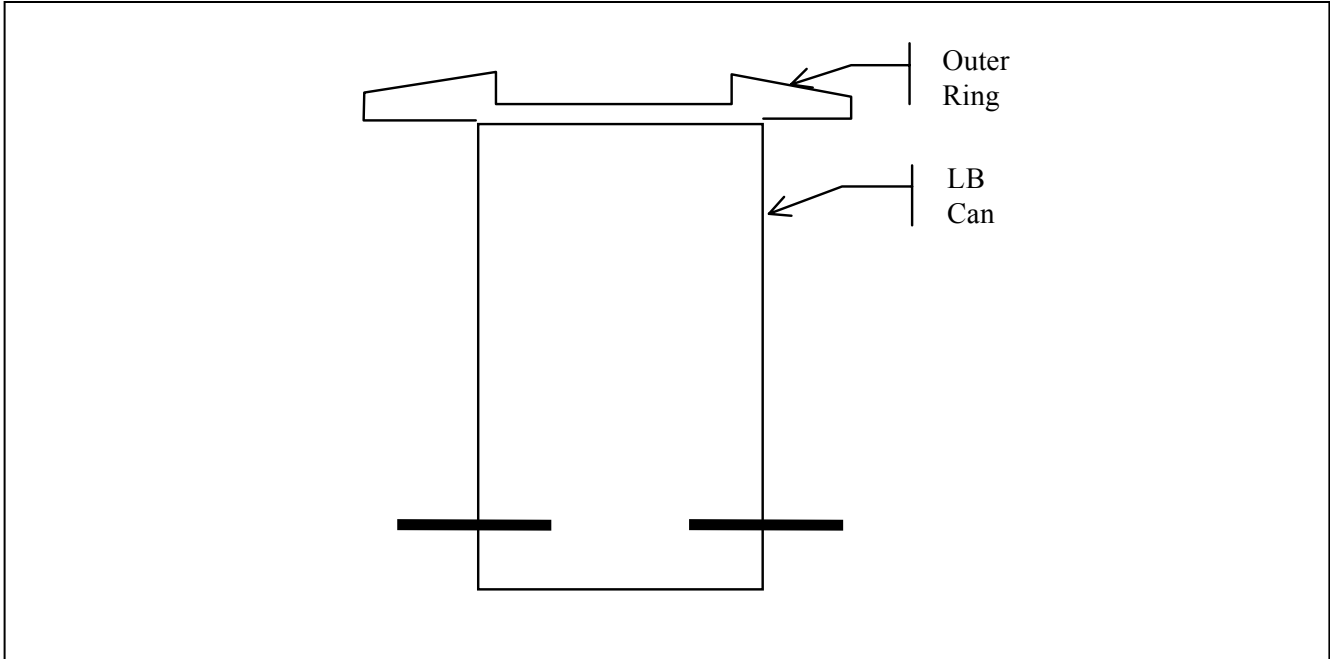

Figure 3-3 Existing 20 A, 500 W Fixture and Transformer Removed from LB-4 Can

- 3. See Figure 3-4. Substitute the new 20 A/6.6 A, 300 W transformer.

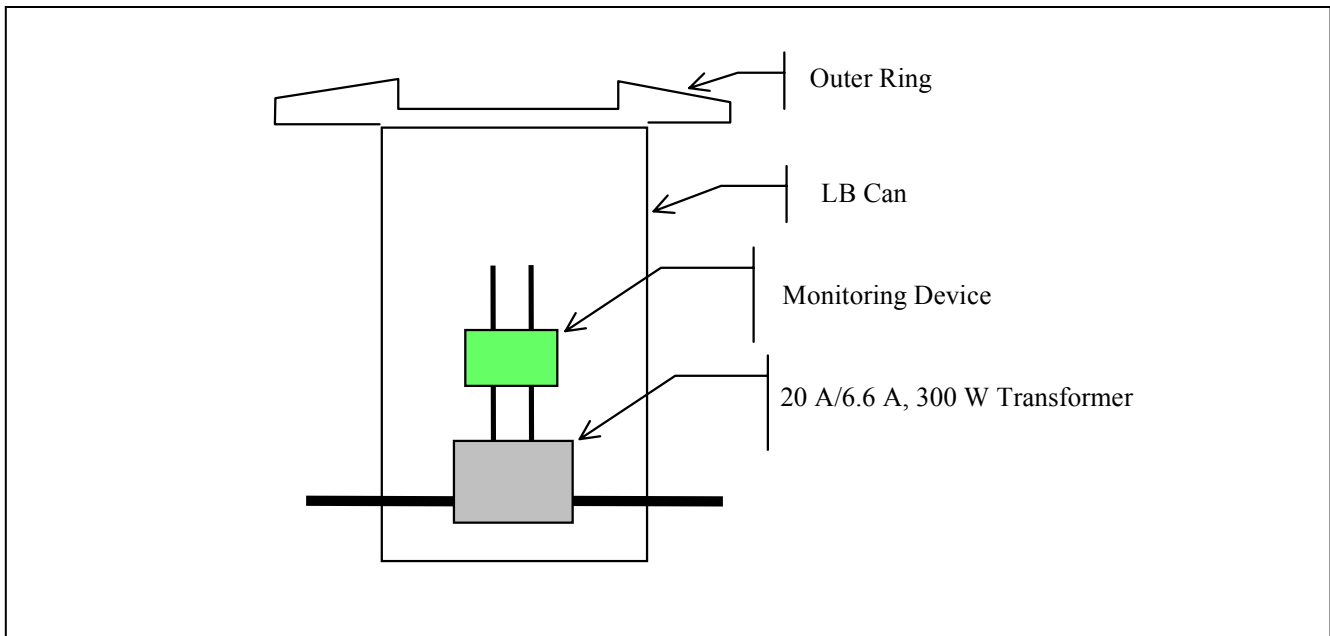

Figure 3-4 New Transformer Substituted

6. Installation in Existing LB-4 Light Bases (contd.)

- Depending on monitoring system manufacturer, add an interface box.

NOTE: For the Airflo/Godrey ALSF-2 monitoring system, add a box with a 6.6 A shorting device supplied by Siemens Airfield Solutions. The part number for the shorting device is 44A6143. For an NBP monitoring system, contact NBP for further information. If there are any further questions, contact Siemens Airfield Solutions for information about monitoring requirements.

- See Figure 3-5. Add a new stainless steel adapter ring.

NOTE: The part number of the SS adapter ring that must be used is AR1-8-SS. It is also required that special SS bolts and lockwashers supplied with the adapter ring be used.

- Install the F-Range high intensity Style 2 approach light using the special SS bolts supplied with the SS adapter ring.

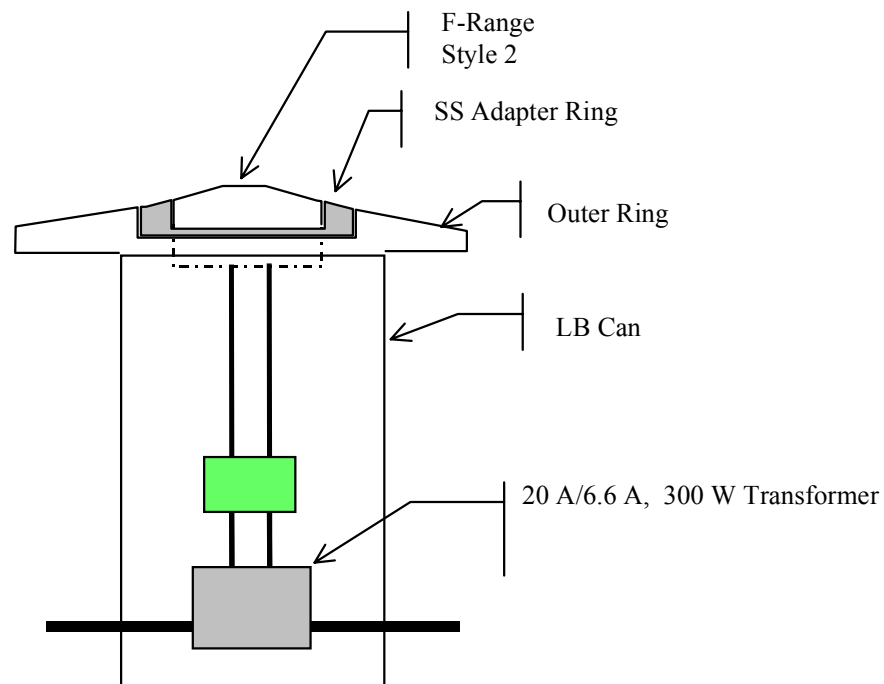

Figure 3-5 Add New Adapter Ring and Light Fixture

Section 4

Maintenance

1. Introduction

This section provides maintenance information and procedures for the F-Range high intensity Style 2 approach light.

2. Maintenance Schedule

Service life depends upon the entire assembly being waterproof. All surfaces must be clean, dry and free of all foreign matter and all bolts must be properly tightened if the light fixture is to operate for extended periods without requiring maintenance.

To keep the F-Range light fixtures operating efficiently, follow a preventive maintenance schedule. Refer to Table 4-1. Refer to FAA AC 150/5340-26 for more detailed information.

Table 4-1 F-Range Light Fixture Maintenance

Interval	Maintenance Task	Action
Daily	Check for burned-out lamp. Check for dim lamp.	Replace lamp. Refer to <i>Replacing Lamp</i> in this section. Clean optical surface if dirty. Check for misalignment or presence of moisture in fixture.
Weekly	Check for dirty channel and lens.	Clean channel and prism. Refer to <i>Cleaning Light Channel and Prism</i> in this section.
Monthly (or more frequently during rainy seasons)	Check for moisture in the light fixture.	Open up the light fixture. Clean, dry, and inspect the light assembly. Replace O-ring.
Every 60 days, or whenever the light assembly is serviced	Check for improper torque on holddown bolts.	Torque six bolts holding fixture to base receptacle to 185 ± 5 inch-pounds (20.902 ± 0.565 Nt-M). Use Loctite to keep bolts tight. Refer to <i>Retorquing Mounting Bolts</i> in this section.
Semi-annually	Check for six inches (152 mm) of water in the L-868 base.	Pump water from base. Remove and inspect light for water damage. Refer to <i>Removing L-868 Base Water</i> in this section.
After snow removal	Check for damaged light fixtures.	Replace damaged fixtures. Use a power broom for snow removal, if practical. Follow recommended snow removal techniques described in AC 150/5200-23.

3. Maintenance Procedures

This subsection describes the following maintenance procedures:

- replacing lamp
- cleaning light channel and prism
- retorquing mounting bolts
- removing L-868 base water
- lifting optical unit out of base
- testing for leaks

Replacing Lamp



WARNING: Turn off the circuit before replacing lamp(s). Failure to observe this warning may result in personal injury, death, or equipment damage.



WARNING: Allow time for the unit to cool. High interior temperatures may cause severe burns to personnel. Failure to observe this warning may result in personal injury.

The preferred method of maintaining the F-Range inset light is to periodically and systematically replace the light assembly and return the replaced assembly to the maintenance shop for renovation. As an alternative, you can service the light assembly in the field. It is recommended, however, that field servicing be limited to cleaning lenses and replacing lamp(s).

NOTE: If any lamps are out, record the location of the fixture and replace the lamp when the circuit is turned off. If one lamp burns out, it is recommended to replace all lamps.

Refer to *Replacing Lamp and Filter* in the *Repair* section for lamp replacement procedure.

Cleaning Light Channel and Prism

To clean the light channel and prism, perform the following procedure:

1. See Figure 2-2. Use a suitable fiber brush to remove all accumulated debris from the light channel (4).

Cleaning Light Channel and Prism *(contd.)*

2. Clean the outer surface of the prism (3) using liquid glass cleaner. If the prism is coated with a substance impervious to the cleaner, apply a suitable solvent sparingly with a wad of cotton or a patch of cloth. After the solvent has acted, remove the softened coating with a clean piece of cotton or cloth. Dry the prism with gently, dry, oil-free compressed air at a pressure no greater than 10 psi (69 Knt/m²) to evaporate or remove all remaining cleaner.

Retorquing Mounting Bolts

When retorquing mounting bolts, apply one drop of Grade AV Loctite to each of the six 3.8-inch- (9.525-mm-) diameter mounting bolts. Torque the bolts to 185 ±5 inch-pounds (20.902 ± 0.565 Nt-m). Torque the bolts across the corners.

See Figure 4-1. To torque the outer bolts across corners, tighten bolts in noted sequence: #1 and #4, then #2 and #5, then #3 and #6.

NOTE: Applying more than one drop of Loctite to the screw and bolt threads will create future difficulty in removal of the bolts.

NOTE: After several relampings, threaded holes may accumulate with dirt and excessive Loctite. If this occurs, screws may not seat properly. Clean holes with light weight oil or diesel fuel using a small fiber brush. Wipe the holes clean with alcohol to remove all oil or diesel fuel and dirt. Clean with dry, oil-free, low-pressure air.

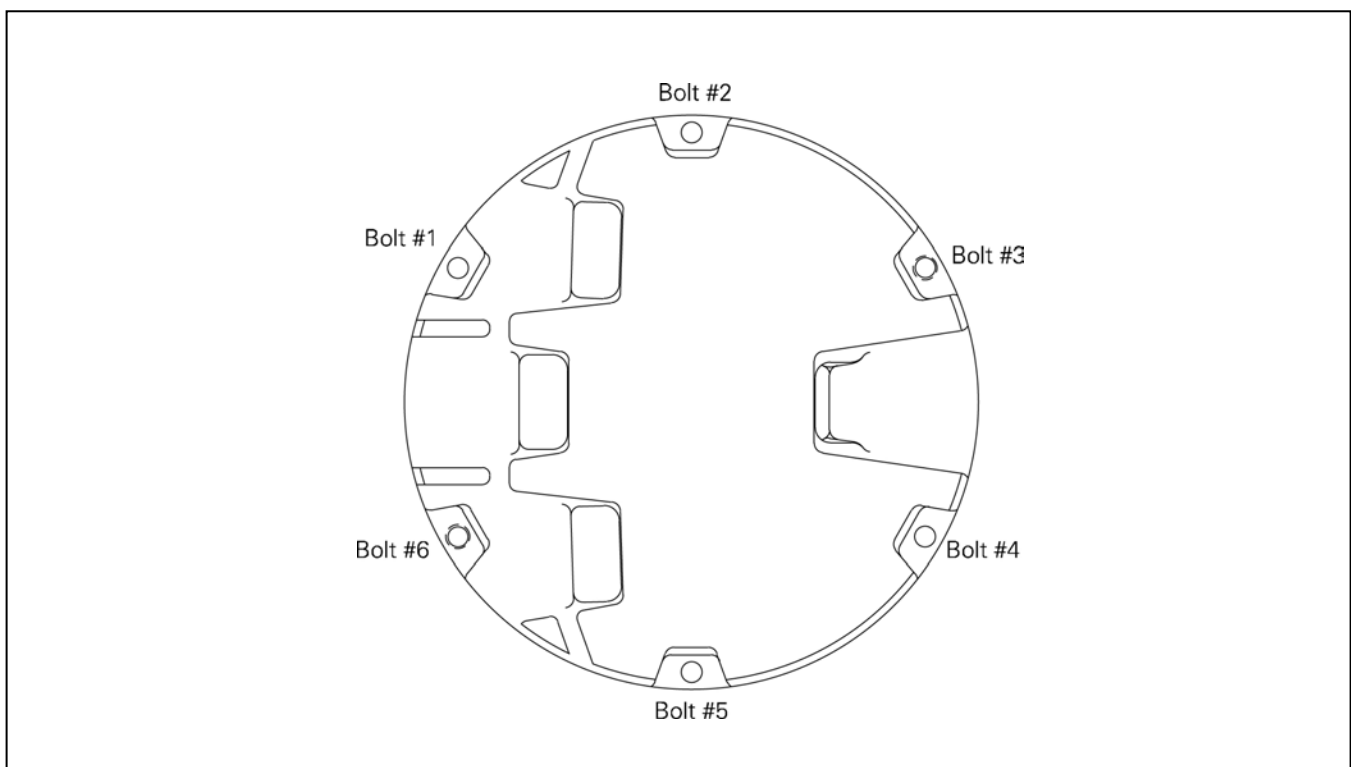

Figure 4-1 Sequence for Torquing Mounting Bolts

Removing L-868 Base Water



Turn off the circuit when checking water level.

Check the water level in the L-868 base on a regular schedule. If more than six inches (152.4 mm) of water in the light base is found, pump the water from the base and remove and inspect the entire light assembly for water damage. Cover the L-868 base with the appropriate steel cover plate after removing the light assembly.



Water entering the L-868 base can become a serious problem, since freezing water can rupture the base.

Lifting Optical Unit Out of Base

To lift the optical unit from the light base, perform the following procedure:

1. Remove the six fixing screws and washers or self locking nuts.
2. Fit the appropriate lifting tool into both threaded holes located (180 degrees apart) in the cover, lift the optical unit out of the base and place the optical unit next to the base.
3. Disconnect the light fixture wires from the power wires coming from the transformer(s).
4. Mount a serviced or new light fixture as described in *Installation on L-868 Base* in the *Installation* section.

NOTE: Torque the six screws to 20.902 ± 0.565 Nt-m (185 \pm 5 inch-pounds).

5. Take the inset fixture unit back to the maintenance base where it can be serviced entirely.



Never hold the light fixture by the wires. This may damage the insulation, break the waterproof seal, and cause insulation faults and water leakage.

Testing for Leaks

To test for leaks, perform the following procedure:

1. See Figure 4-2. Remove pressure release screw (E11).

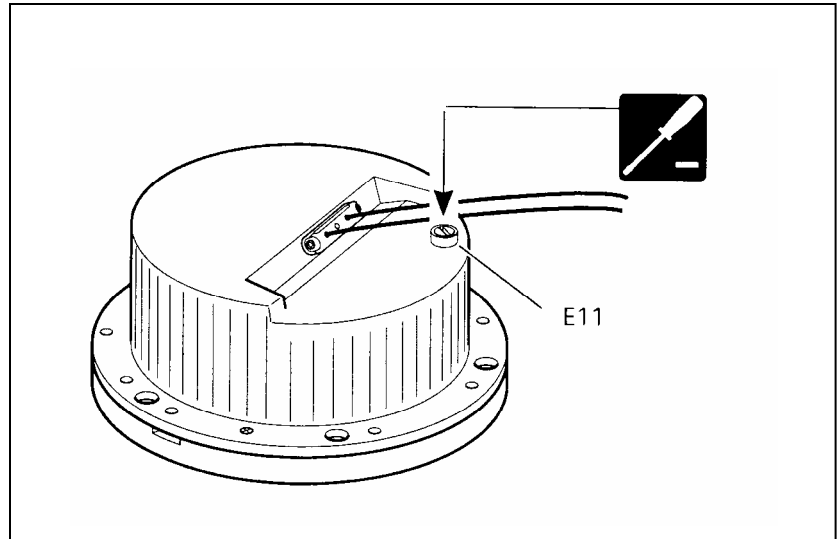

Figure 4-2 Pressure Release Screw

2. See Figure 4-3. Screw pressure test fitting (1) into the pressure release port (the opening created when the pressure release screw is removed). Screw fitting hand-tight.

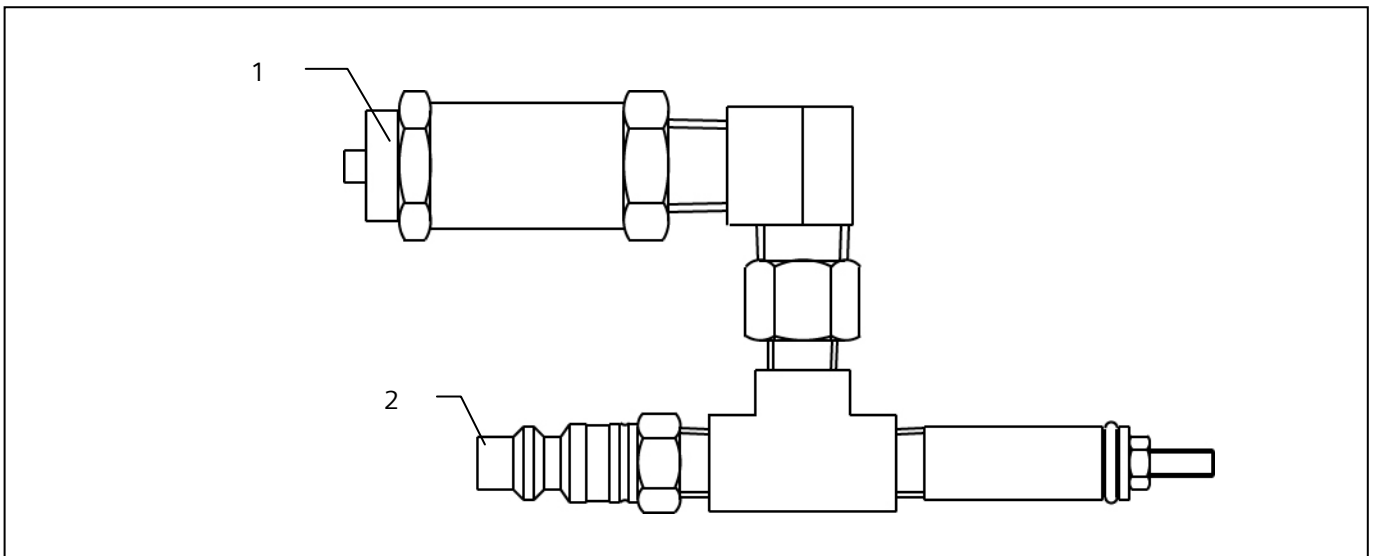

Figure 4-3 Pressure Test Fitting Assembly

1. Pressure Test Fitting
2. Lock Hose Plug Sleeve

Testing for Leaks *(contd.)*

3. Attach the shop airline to the lock hose plug sleeve (2).
4. Pressurize to 20 psi.
5. Submerge the pressure test fitting in a water tank. Check for air bubbles. Air bubbles indicate a leak.
6. Locate the leak source, depressurize, replace the seal that is leaking, reassemble, and retest by following steps 4 and 5.
7. See Figure 4-2. If leak is fixed, depressurize and reinstall the pressure release screw (E11).

Section 5

Troubleshooting



WARNING: Allow only qualified personnel to perform the following tasks. Observe and follow the safety instructions in this document and all other related documentation.



WARNING: De-energize the circuit and lock out the circuit or regulator so that the circuit cannot be energized by remote means before attempting to service the fixture.

1. Introduction

This section contains troubleshooting information. This information covers only the most common problems that you may encounter. If you cannot solve the problem with the information given here, contact your local Siemens Airfield Solutions representative for help.

Problem		Page
1.	Lamp not energizing	5-2
2.	Lamp not turning on at normal level	5-2
3.	Lamp output distorted	5-2
4.	Improper color	5-2
5.	Short lamp life	5-2
6.	Distorted light beam output	5-2
7.	Water inside optical chamber	5-2

2. Troubleshooting Procedures

Troubleshooting procedures for the F-Range inset lights are contained here.

Problem	Possible Cause	Corrective Action
1. Lamp not energizing	Defective lamp	Replace lamp. Refer to <i>Replacing Lamp</i> in the <i>Maintenance</i> section.
	Loose or broken contacts	Tighten or replace.
	Moisture inside assembly causing current leakage	Open up light assembly. Clean, dry, and inspect light assembly. Replace O-ring.
	Defective isolation transformer	Check transformer output current with meter.
	Defective Voltage Ratio Transformer MALSR ONLY	Verify input current to lamps is correct. Also verify voltage is present across the primary of the transformer
2. Lamp not turning on at normal level	Continuity incorrect	Check lamp filament and wiring for continuity.
3. Lamp output distorted	Broken or damaged lens	Replace lens.
4. Improper color	Filter broken	Replace filter.
	Filter bracket broken	Replace filter bracket assembly.
5. Short lamp life	Current too high	Check constant current regulator and isolation transformer.
	Current too high (MALSR ONLY)	Check to see if input voltage is too high Or if voltage transformer is defective.
	Water in assembly	Inspect prism. Open light assembly. Clean, dry and inspect light assembly. Replace O-ring.
	Defective lamp	Replace lamp. Refer to <i>Replacing Lamp</i> in the <i>Maintenance</i> section. NOTE: Lamp interior will have a white powdery appearance if air has entered through a hole or crack.
	Overvoltage	Check to see if lamp has black burns. If so, check isolation transformer output with meter. Replace isolation transformer, if defective.
6. Distorted light beam output	Cracked or damaged lens	Replace lens.
7. Water inside optical chamber	Damaged or missing lens seals or top cover O-ring	Replace both lens seals. Replace top cover O-ring.
	Cut or nick on L-823 cordset insulation that exposes wire	Replace insulation.

Section 6

Repair

1. Introduction

This section describes procedures for repairing and replacing parts. It includes opening the optical unit, and replacing the lamp and filter, prism, optical unit, and L-823 cordset. It also describes how to close the optical unit.

2. Opening Optical Unit

To open the optical unit, perform the following procedure:

1. Turn the light unit upside-down.
2. See Figure 6-1. Remove the pressure release screw (E11).

NOTE: Removing the pressure release screw equalizes the pressure inside and outside the fixture, making it easier to break the seal and remove the inner cover.

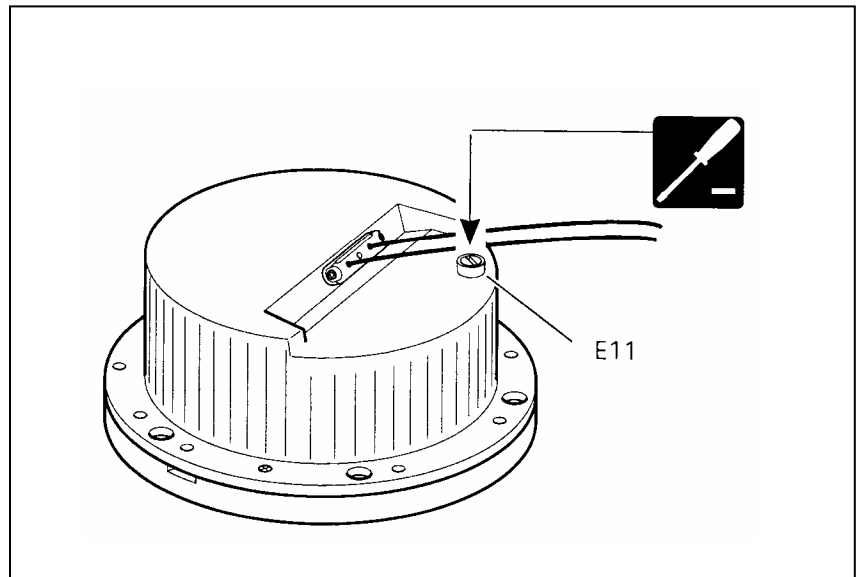

Figure 6-1 Pressure Release Screw

2. Opening Optical Unit (contd.)

3. See Figure 6-2. Remove the ten screws (E10). The use of an impact driver may be required to unlock the screws.

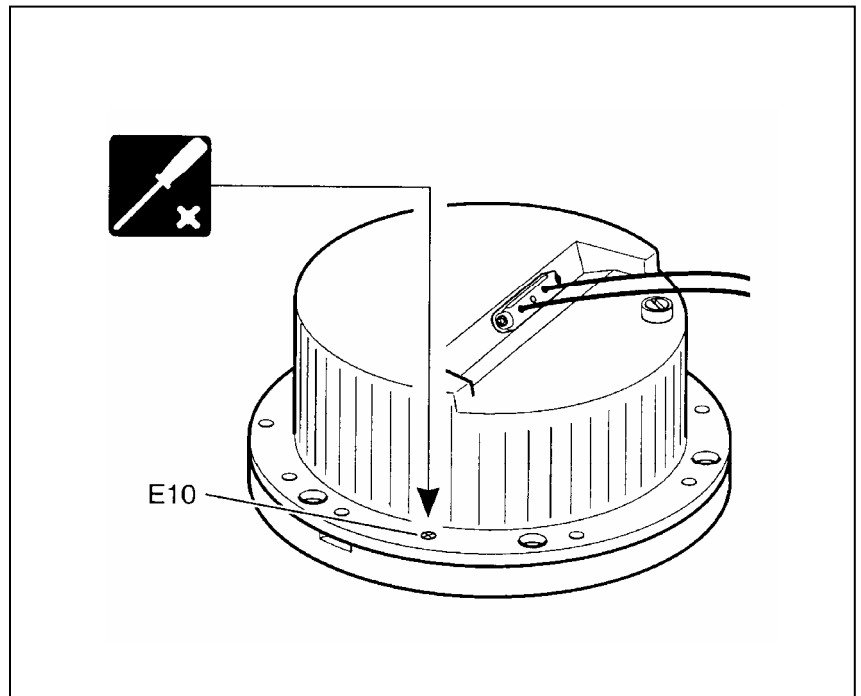

Figure 6-2 Removing Screws

4. See Figure 6-3. Insert small or medium flat blade screwdriver in the machined recess slot between cover and inner cover and turn it vertically to separate the inner cover from the cover.

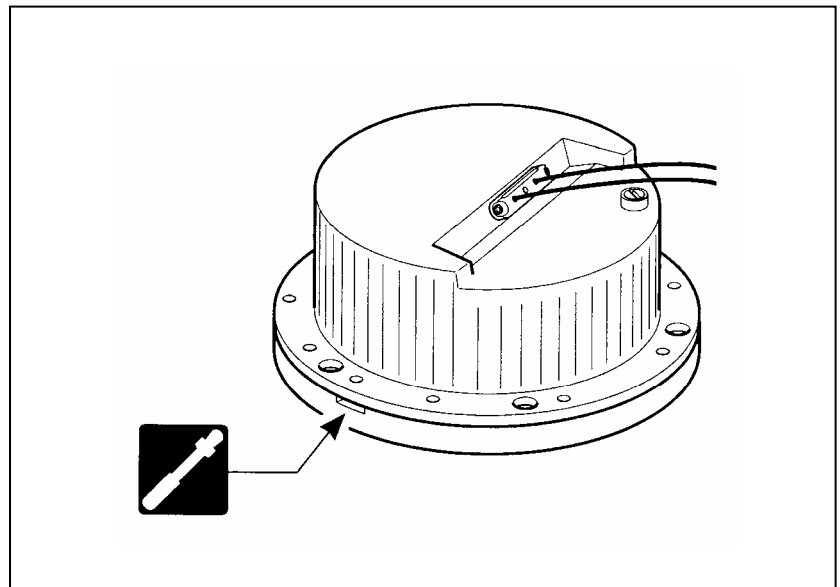

Figure 6-3 Separating Inner Cover from Top Cover

3. Replacing Lamp and Filter



WARNING: Turn off the circuit before replacing lamp(s). Failure to observe this warning may result in personal injury, death, or equipment damage.



WARNING: Allow time for the unit to cool. High interior temperatures may cause severe burns to personnel.

Refer to Table 6-1 for parts referred to in Figures 6-4 and 6-5.

Table 6-1 Parts List for Replacing Lamp and Filter

Item	Part Number	Description	Quantity	Note
Item 1 on Figure 6-4	4071.50.160	Filter spring	1	
Item 2 on Figures 6-4 and 6-5	2990.40.900	Lamp, 105 W	3	
Item 3 on Figure 6-4		Filter		
	63A0968	Filter, red	See note.	A
	63A0963	Filter, green	See note.	A
Item 4 on Figures 6-4 and 6-5	1411.22.002	Lamp holder assembly	See note.	B, C
Item 5 on Figures 6-4 and 6-5	See note.	Lamp clip	3	F
Item 6 on Figure 6-5	44A6192-2	Modified lamp holder assembly, left-hand	See note.	D
Item 7 on Figure 6-5	44A6192-1	Modified lamp holder assembly, right-hand	See note.	E

NOTE A: Quantity is 3 for the 44A6152-10 (red or green) optical support assembly.

NOTE B: Quantity is 3 for the 44A6152-10 optical support assembly, 1 for the 44A6152-20 optical support assembly (located in the center of the optical support plate).

NOTE C: Lamp holder assembly is also shown on Figure 6-6, Item 4.

NOTE D: Quantity is 1 for the modified lamp holder assembly left-hand for the 44A6152-20 optical support assembly.

NOTE E: Quantity is 1 for the modified lamp holder assembly right-hand for the 44A6152-20 optical support assembly.

NOTE F: The lamp clip is a part of the lamp holder assembly, part number 1411.22.002. It cannot be ordered separately.

3. Replacing Lamp and Filter (contd.)

To replace the lamp and filter, perform the following procedure:

1. Open the optical unit. Refer to *Opening Optical Unit* in this section.
2. See Figure 6-4 for the red or green optical support assembly and Figure 6-5 for white optical support assembly.

For the red or green optical support assembly, remove the filter spring (1), filter (3), lamp (2), and lamp clip (5) from the lamp holder assembly (4).

-OR-

For the white optical support assembly, remove the lamp (2) and lamp clip (5) from the lamp holder assembly (4).

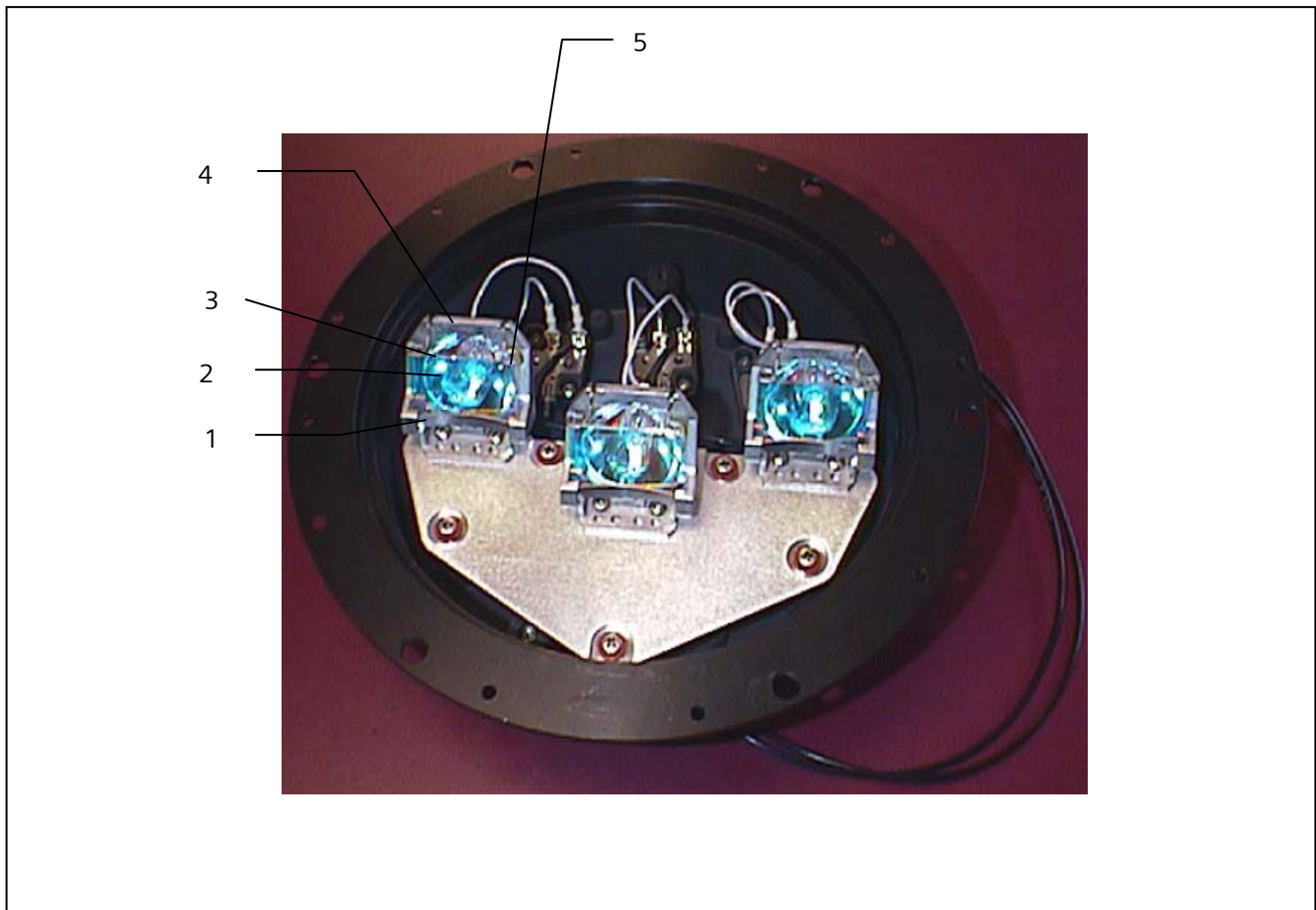

Figure 6-4 Red or Green Optical Support Assembly

3. Replacing Lamp and Filter *(contd.)*



Figure 6-5 White Optical Support Assembly

3. Replacing Lamp and Filter *(contd.)*

3. Replace with new lamp and new filter.

NOTE: See Figure 6-6. To optimize photometric output, make sure that the lamp is correctly positioned with the arrow pointing up.



Never touch the bulb of the lamp with your bare hands. It will reduce the lifetime of the lamp considerably. Should it happen, clean the bulb with alcohol.

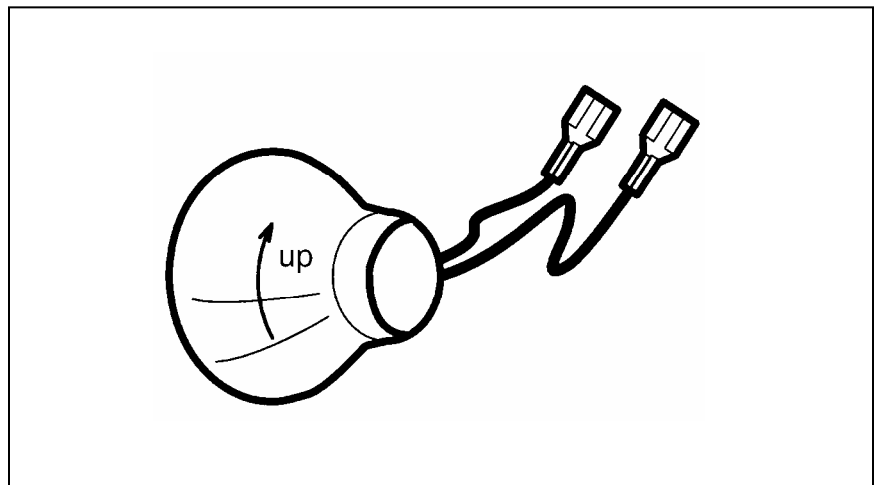

Figure 6-6 Arrow Pointing Up

4. For the red or green optical support assembly, put the filter spring and filter back in. Make sure the curved part of the filter spring faces the filter.
5. Put the two parts of the lamp clip (5) in their respective notches on the lamp holder assembly.

4. Replacing Prism

Replace the prism if it is broken or its surface is badly pitted or scarred.

Refer to Table 6-2 for parts referred to in Figures 6-7 through 6-9.

Table 6-2 Parts List for Replacing Prism

Item	Part Number	Description	Quantity	Note
Item 1 on Figures 6-7, 6-8, and 6-9	1428.00.300	Prism, narrow beam, optical glass	3	
Item 3 on Figure 6-7	4071.50.052	Prism-keeper plate	3	
Item 2 on Figure 6-7	4017.50.360	Prism clamp	3	
Item 4 on Figure 6-7	4071.62.630	Inner pan assembly	1	
Item 5 on Figure 6-7	64A0925-10	Screw, M5 x 10 (for top cover assembly)	6	
Item 6 on Figure 6-7	64A0936-13	Screw, M5 x 13 (for top cover assembly)	6	
Item 7 on Figure 6-8	63A0986	Flat seal	3	
Item 8 on Figure 6-9	4071.50.030	Sock seal	3	

4. Replacing Prism (contd.)

To replace the prism, perform the following procedure:

1. See Figure 6-7. Remove the prism-clamp (2) and prism-keeper plate (3) secured in the inner pan assembly (4).

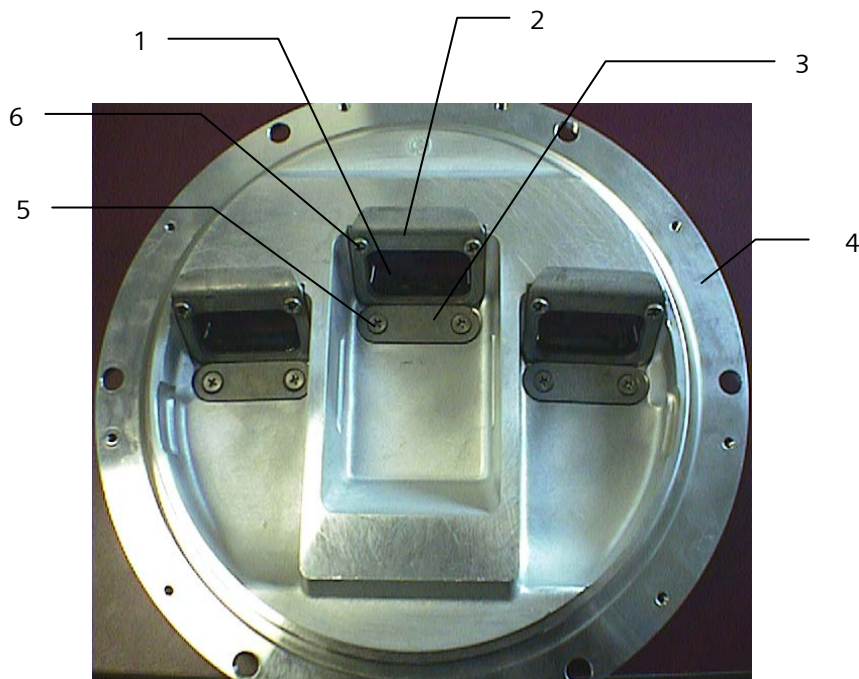

Figure 6-7 Replacing Prism

4. Replacing Prism (contd.)

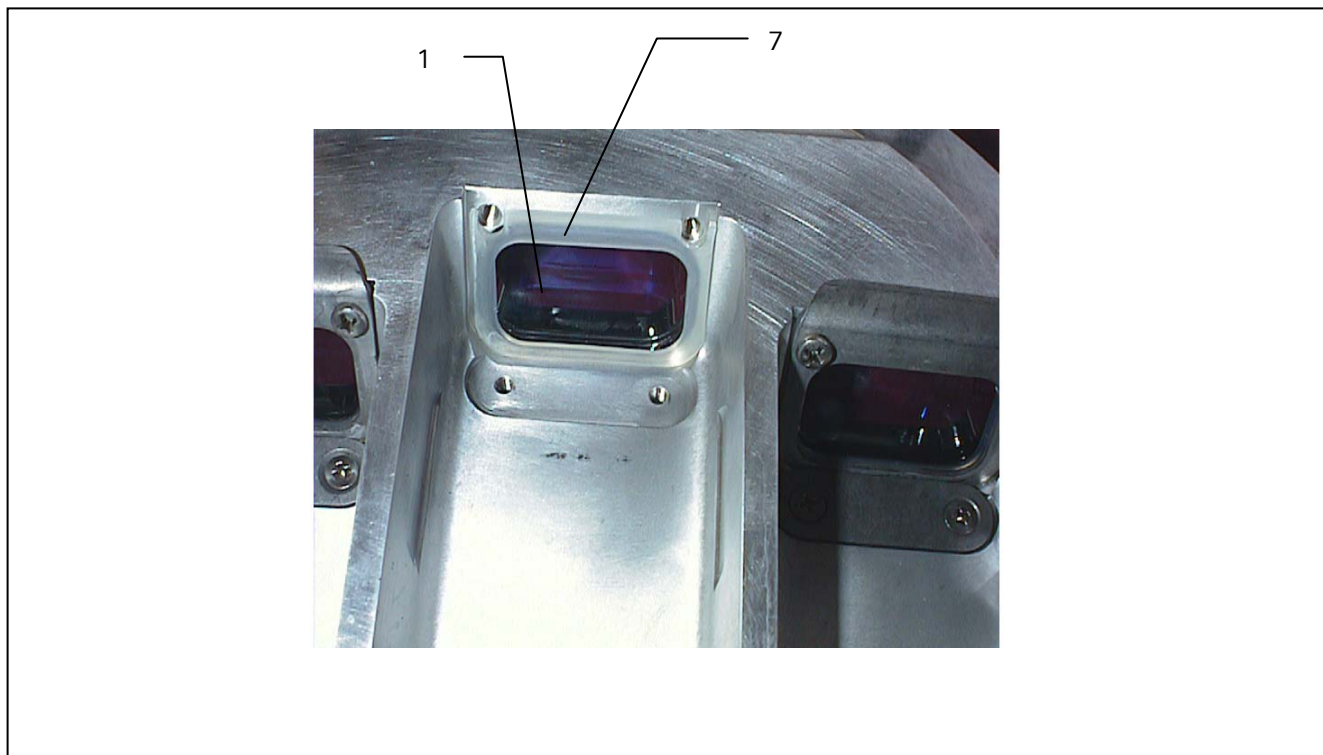

Figure 6-8 Flat Seal for Prism

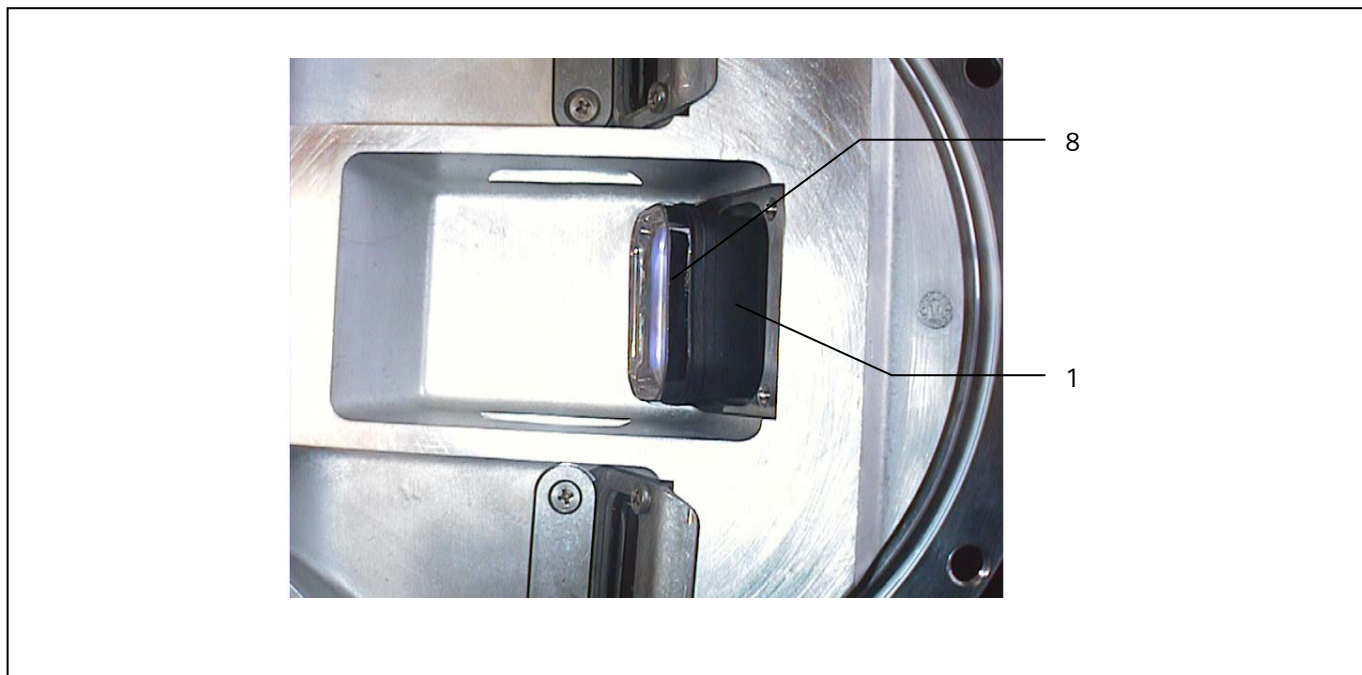

Figure 6-9 Sock Seal for Prism

4. Replacing Prism (contd.)

2. See Figure 6-8. Remove the flat seal (7).
3. See Figure 6-9. Push the prism (1) with the sock seal (8) towards the inside of the cover.
4. Clean and degrease the prism chamber with any effective solvent.



Never use any abrasive substance. This will scratch or frost the prism.

5. Apply a thin layer of lubricant MOLYKOTE BG87 INERTA or MOLYKOTE BG88 INERTA in the prism chamber using a small brush.
6. Install a new sock seal over the prism.
7. Push the prism/gasket assembly in the prism pocket from the inside and clean the inner surface of the prism.
8. Install a new flat seal over the prism-keeper plate.
9. See Figure 6-7. Reinstall hardware with the Phillips pan head screws (5, 6). Apply a droplet of sealant Loctite 270 to the last threads. Torque to 3.5 ± 0.5 Nt-m (31 ± 4 inch-pounds).

5. Replacing Optical Unit

Refer to Table 6-3 for parts referred to in Figure 6-10.

Table 6-3 Parts List for Replacing Optical Unit

Item	Part Number	Description	Quantity	Note
1	44A6152-10 44A6152-20	Optical unit Optical unit, 3 lamp, red or green Optical unit, 3 lamp, white	1	
2	44A6153-01	Inner pan assembly	1	
4	63A0222	Grommet (for optical bracket)	5	
5	64A0936-13	Screw, M4 x 10 (for optical bracket)	5	

5. Replacing Optical Unit*(contd.)*

To replace the optical unit, perform the following procedure:

1. Remove the lamp(s). Refer to *Replacing Lamp and Filter* in this section.
2. See Figure 6-10. Remove the optical unit (1) by loosening screws (5).

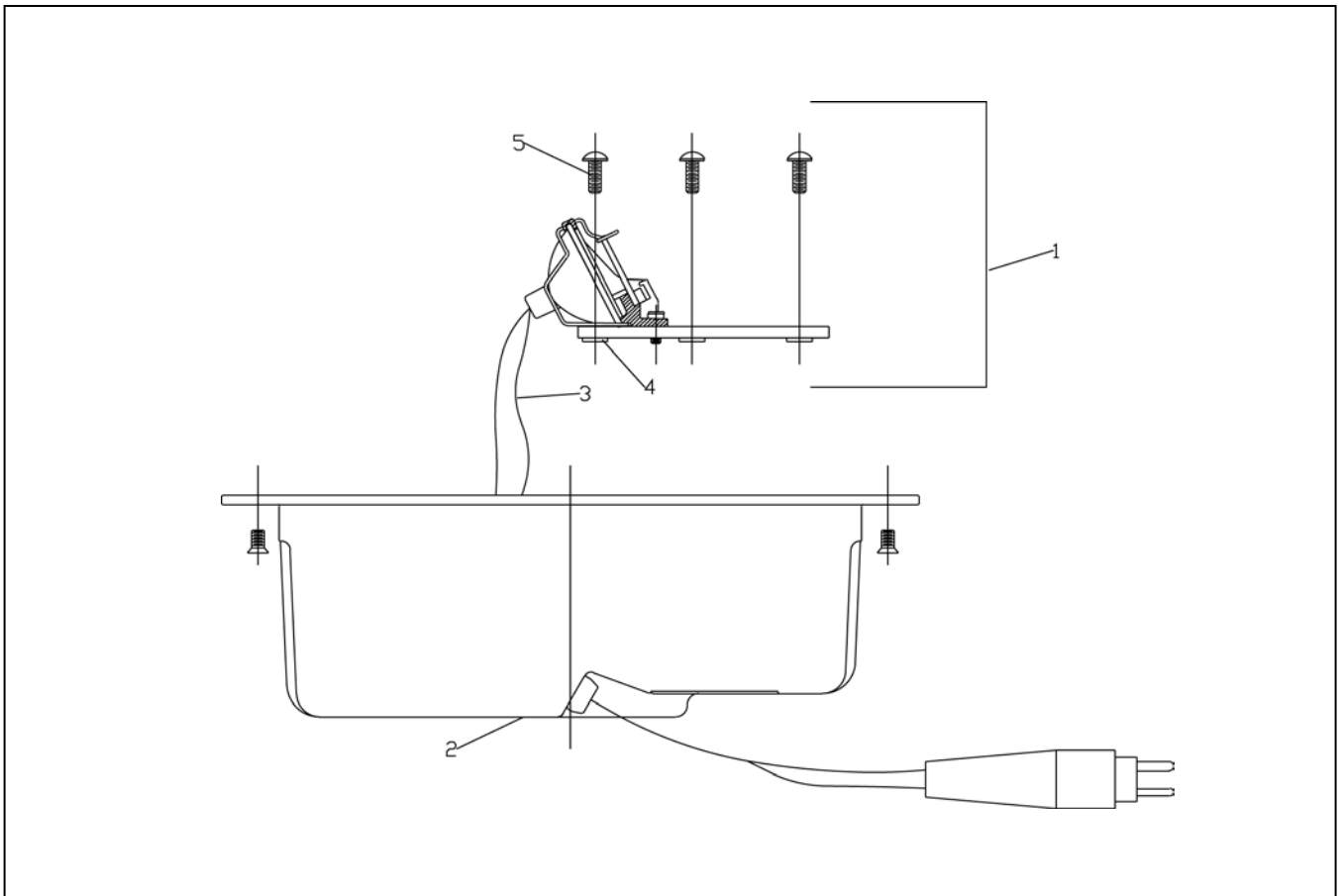

Figure 6-10 Removing Optical Unit from Inner Pan Assembly

3. Position the new optical unit with new grommets (4).
4. Torque the fixing screws to 3.5 ± 0.5 Nt-m (31 ± 4 inch-pounds).

6. Replacing L-823 Cordset

Refer to Table 6-4 for parts referred to in Figures 6-11 and 6-12.

Table 6-4 Parts List for Replacing L-823 Cordset

Item	Part Number	Description	Quantity	Note
Item E5 on Figure 6-11	62A2145-3	Top cover	1	
Item F5 on Figure 6-11	63A1014	Grommets (for cordset)	2	
Item F6 on Figure 6-11	4071.50.090	Wire clamp (for cordset)	1	
Item F7 on Figure 6-11	7110.08.367	Screw, M4 x 10 (for cordset)	2	
Item F8 on Figure 6-11	73A0133-31	Cordset	1	
Item 8 on Figure 6-12	6111.87.140	Fast-on connector	2	

To replace the L-823 cordset, perform the following procedure:

1. Open the optical unit. Refer to *Opening Optical Unit* in this section.
2. Remove the optical unit. Refer to *Replacing Optical Unit* in this section.

6. Replacing L-823 Cordset (contd.)

- See Figure 6-11. Remove both screws (F7) and the wire clamp (F6).

NOTE: Replace the wire grommets (F5) when damaged or aged.

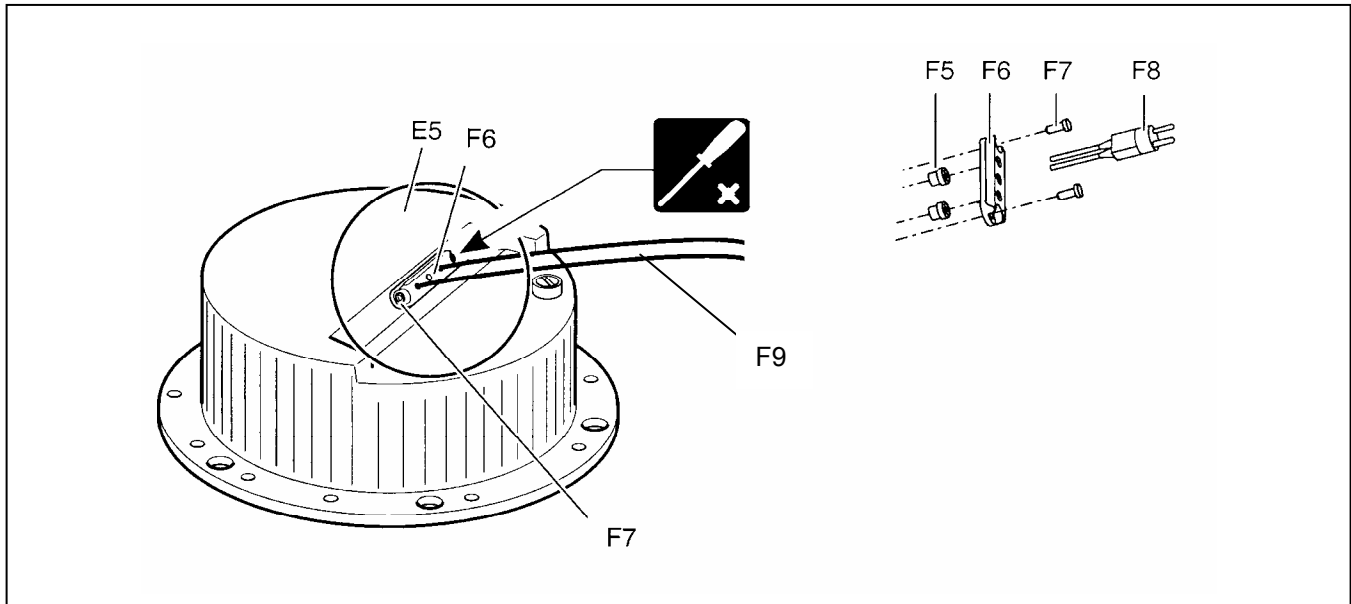

Figure 6-11 L-823 Cordset

6. Replacing L-823 Cordset (contd.)

4. See Figure 6-12. Unplug the fast-on connectors (8) from the cable assembly wiring (7).

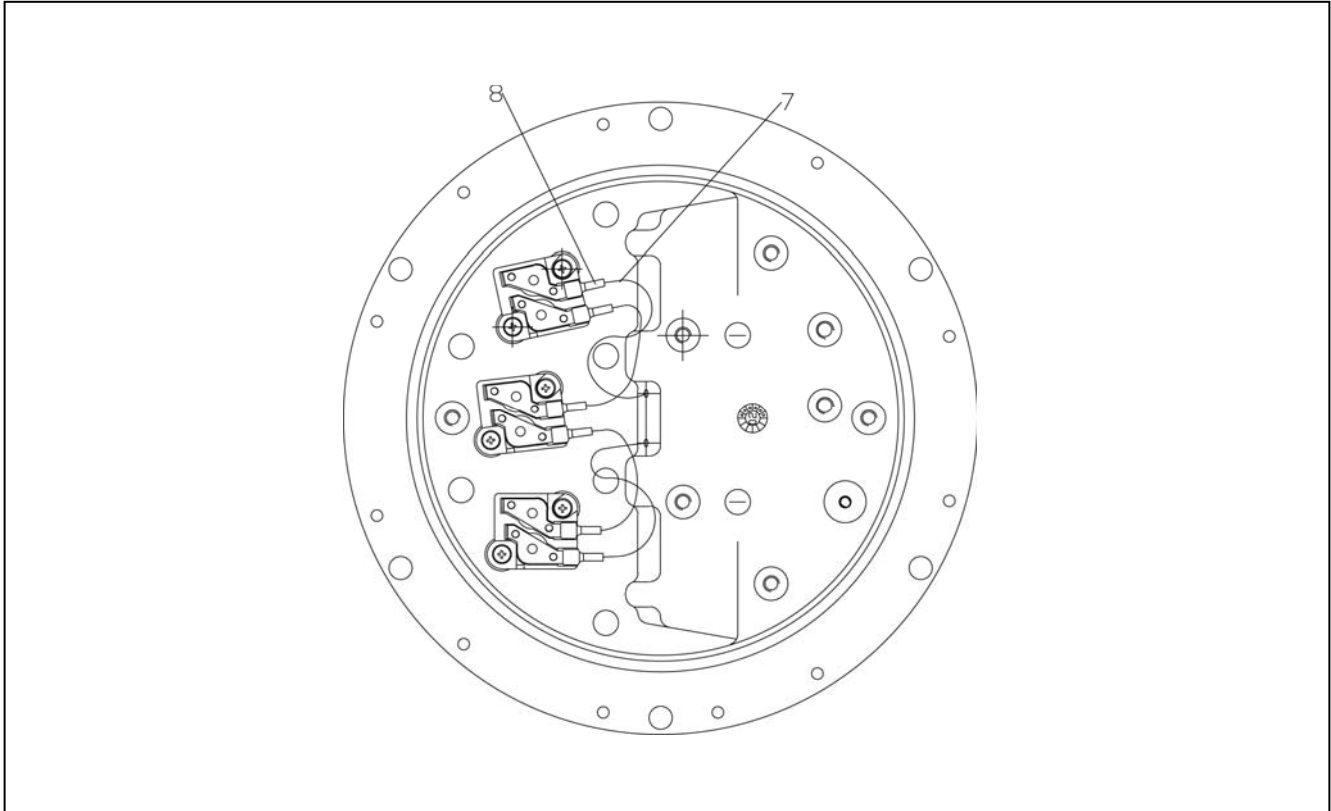

Figure 6-12 Fast-On Connectors

5. See Figure 6-11. Pull the cordset cable assembly (F9) out of the inner cover and discard the wire grommets (F5).
 6. Bring the new cable assembly (F9) through the wire clamp (F6).
 7. Put a new wire grommet (F5) on each of the wires, taking care of the direction. Put the smaller diameter into the inner cover recesses.
 8. Install the wires in the inner cover.
 9. Reinstall the wire clamp (F6) by means of both cross recessed countersunk screws (F7).
- NOTE:** Do not torque down the screws entirely at this step.
10. Remove the insulation of the wires over about 5 mm.

6. Replacing L-823 Cordset (contd.)

11. Crimp on the new fast-on connectors and connect them to the terminals. Adjust the wires inside the inner cover.

12. Torque the screws (F7) to 31 ± 4 inch-pounds (3.5 ± 0.5 Nt-m).

7. Closing Optical Unit

Refer to Table 6-5 for parts referred to in Figure 6-13.

Table 6-5 Parts List for Closing Optical Unit

Item	Part Number	Description	Quantity	Note
1	63B0267-011	O-ring (for top cover)	1	
2	62A2145-3	Top cover	1	
3	1428.00.300	Prism	3	
4	1411.22.002	Lamp holder assembly	See note.	A, B
4	44A6192-2	Modified lamp holder assembly, left-hand	See note.	C
4	44A6192-1	Modified lamp holder assembly, right-hand	See note.	D
5	2990.40.900	Lamp, 105 W	3	
6		Optical unit	1	
	44A6152-10	Optical unit, 3 lamp, red or green		
	44A6152-20	Optical unit, 3 lamp, white		
7	4071.62.630	Inner cover (of inner pan assembly)	1	
8	64A0925-10	Screw, M5 x 10	6	

NOTE A: Quantity is 3 for the 44A6152-10 (red or green) optical support assembly.
 NOTE B: Lamp holder assembly is also shown on Figure 6-6, Item 4.
 NOTE C: Quantity is 1 for the modified lamp holder assembly left-hand for the 44A6152-20 optical support assembly. See also Figure 6-5.
 NOTE D: Quantity is 1 for the modified lamp holder assembly right-hand for the 44A6152-20 optical support assembly. See also Figure 6-5.

7. Closing Optical Unit*(contd.)*

To close the optical unit, perform the following procedure:

1. See Figure 6-13. Turn the top cover (2) upside down.

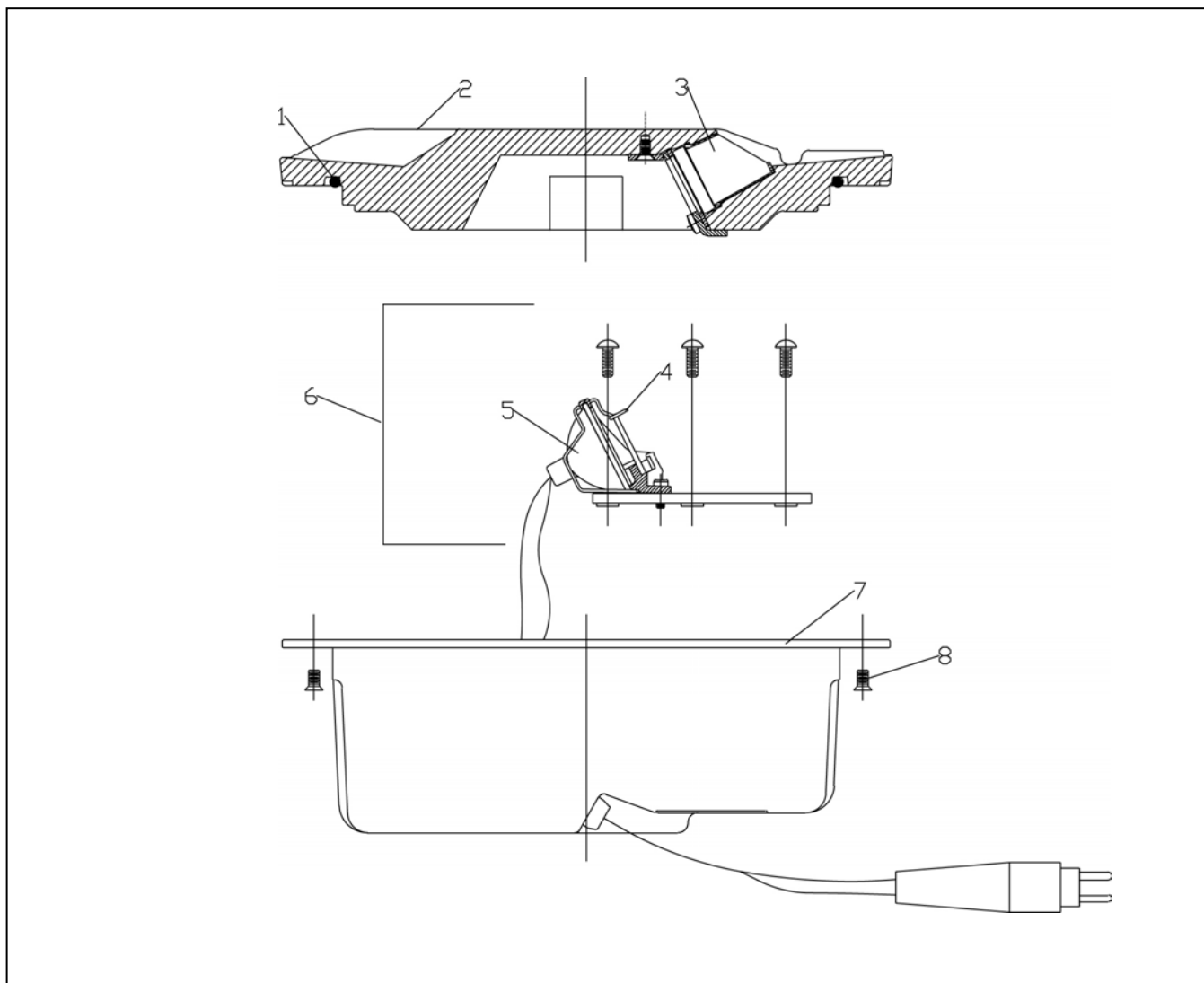

Figure 6-13 F-Range High Intensity Style 2 Approach Light Fixture

7. Closing Optical Unit

(contd.)

2. Make sure that the contact surfaces with the O-ring (1) are clean and apply a light coat of high quality neutral silicone grease.
3. Install a new greased O-ring (1) in the groove located in the top cover.

NOTE: Use a synthetic grease such as MOLYKOTE BG87 INERTA or MOLYKOTE BG88 INERTA.

4. See Figure 6-1. Remove the pressure release screw (E11).
5. See Figure 6-13. Install the inner cover (8) on top of the cover (2).

NOTE: Align the inner pan mounting holes on the top cover holes.

6. Make sure the lamp holder assembly (6) and lamp (5) are correctly positioned and that the wires of the lamps do not get damaged between both parts (top cover and inner cover).
7. Press the inner cover of the inner pan assembly on the top cover and secure with the countersunk screws (9). Apply a droplet of Loctite 222 to the last threads. Torque screws to 22 ± 4 inch-pounds (2.5 ± 0.5 Nt-m).
8. Check the watertightness of the assembly by replacing the pressure release screw with a pressure test fixture. The leak path can then be located by submerging the assembly in a tank of water while pressurizing using shop air pressure to a maximum of 20 psi. Refer to *Testing for Leaks* in the *Maintenance* section.
9. Make sure the O-ring seal for the pressure release screw is in good condition and reinstall the pressure release screw.

Section 7

Parts

1. Introduction

To order parts, call Siemens Airfield Solutions Customer Service or your local representative. Use this four-column parts list, and the accompanying illustration, to describe and locate parts correctly.

2. Using the Illustrated Parts List

This subsection describes how to use the illustrated parts list covered later in this section. It does not provide the actual parts list.

The Part Number column gives the Siemens Airfield Solutions part numbers in numerical order.

The Description column gives the part name, as well as its dimensions and other characteristics when appropriate. Indentions show the relationships between assemblies, subassemblies, and parts.

Part Number	Description	Quantity	Note
XXXXXXXX	Assembly	1	A
XXXXXXXX	Part	1	
XXXXXXXX	Part or Assembly		
XXXXXXXX	Assembly	1	
NOTE A			

The Quantity column contains the quantity required per unit, assembly, or subassembly. The code AR (As Required) is used if the part number is a bulk item ordered in quantities or if the quantity per assembly depends on the product version or model.

The Note column contains letters that refer to notes at the end of each parts list. Notes contain special ordering or product/part version information.

3. F-Range High Intensity Style 2 Approach Light Part Numbering System

Figure 7-1 shows how to determine the part number for a particular F-Range high intensity Style 2 approach light fixture.

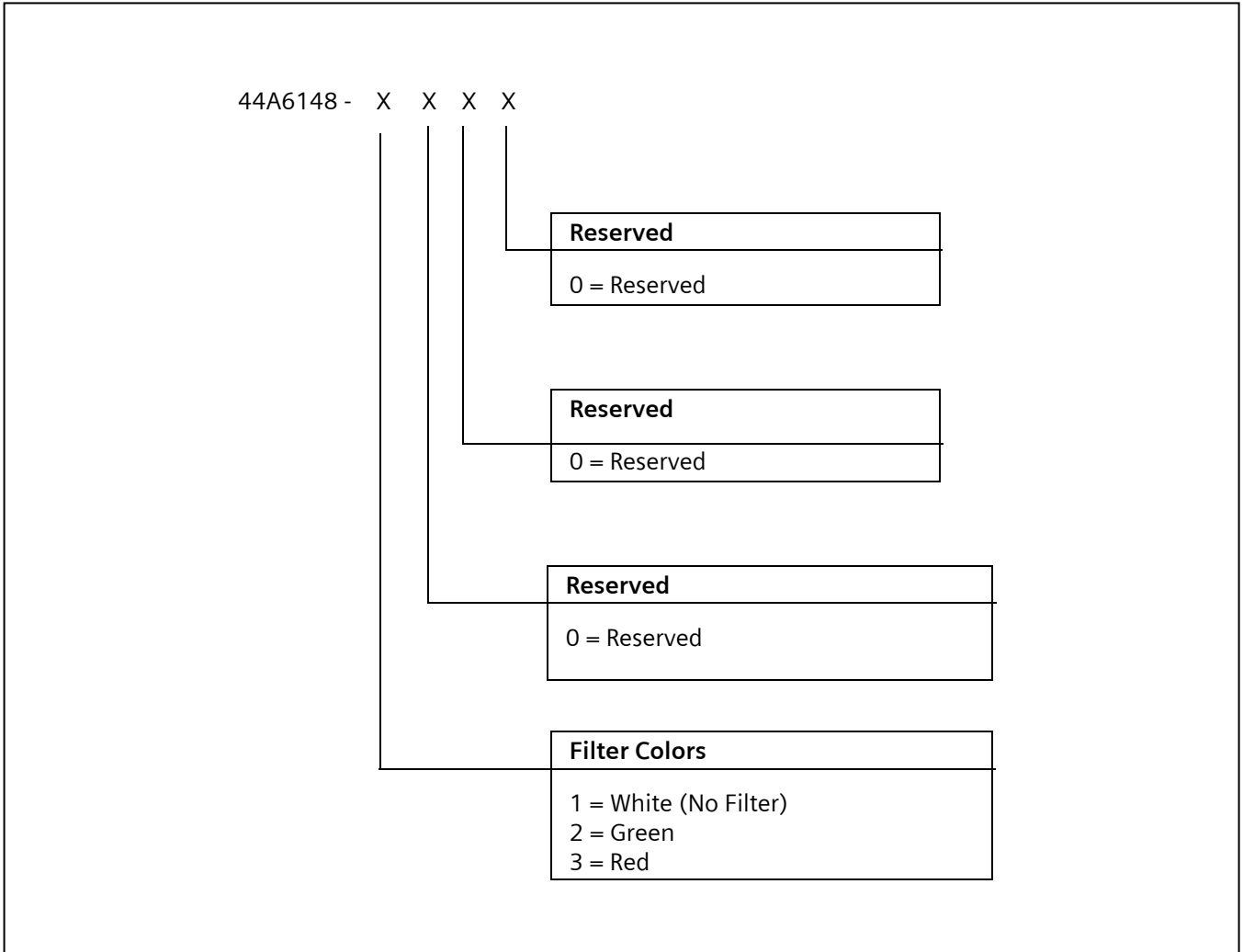

Figure 7-1 F-Range High Intensity Style 2 Approach Light Part Number

4. F-Range High Intensity Style 2 Approach Light Parts List

See Figure 7-2.

Part Number	Description	Quantity	Note
44A6112-1	Terminal block assembly (without film disc cutout)	3	
44A6143	Optional lamp shorting device	1	A
44A6151-10	Top cover	1	
44A6152-10	Optical unit (for red or green filters)	1	
44A6152-20	Optical unit (for no filters/white)	1	
44A6153-10	Inner pan assembly	1	
44A6192-1	Modified lamp holder assembly, right-hand	See note.	B
44A6192-2	Modified lamp holder assembly, left-hand	See note.	C
60A2602	Pressure release screw	1	
60A2854-1	Optical support bracket (red or green)	1	
60A2854-2	Optical support bracket (white)	1	
63A1014	Grommets (for cordset)	2	
63A0222	Grommet (for optical bracket)	5	
63A0963	Filter, green	3	
63A0968	Filter, red	3	
63A0986	Flat seal	3	
63B0267-011	O-ring, pressure screw	1	
64A0925-10	Screw, M5 x 10 Screw, M5 x 10 (for top cover assembly) Screw, M5 x 10 (to connect top cover assembly to inner pan assembly)	10 6	
64A0936-13	Screw, M5 x 13 (for top cover assembly)	6	

NOTE A: The lamp shorting device is not shown on Figure 7-2.

NOTE B: Quantity is 1 for the modified lamp holder assembly right-hand for the 44A6152-20 optical support assembly. See also Figure 6-5 in Section 6, *Repairs*.NOTE C: Quantity is 1 for the modified lamp holder assembly left-hand for the 44A6152-20 optical support assembly. See also Figure 6-5 in Section 6, *Repairs*.

Continued on next page

4. F-Range High Intensity Style 2 Approach Light Parts List (contd.)

Part Number	Description	Quantity	Note
73A0133-31	Cordset	1	
1411.22.002	Lamp and filter holder assembly	See note.	A
1428.00.300	Prism, narrow beam, optical glass	3	
2990.40.900	Lamp, 105 W	3	
4071.50.030	Sock seal	3	
4071.50.052	Prism keeper plate	3	
4071.50.090	Wire clamp (for cordset)	1	
4071.50.160	Filter spring	See note.	B
4017.50.360	Prism clamp	3	
4071.62.630	Inner cover	1	
6111.87.140	Fast-on connector (for inner pan terminal block)	2	
7080.90.710	O-ring (for top cover)	1	
7110.08.367	Screw, M4 x 10 Screw, M4 x 10 (for optical bracket) Screw, M4 x 10 (for cordset)	3 2	
7284.10.416	Spring lockwasher, M4	3	
NOTE A: Quantity is 1 for the 44A6152-20 optical support assembly. Quantity is 3 for the 44A6152-10 optical support assembly.			
NOTE B: Quantity is 3 for the 44A6152-10 optical support assembly. Quantity is 0 for the 44A6152-20 optical support assembly			

**4. F-Range High Intensity
Style 2 Approach Light**
Parts List (contd.)

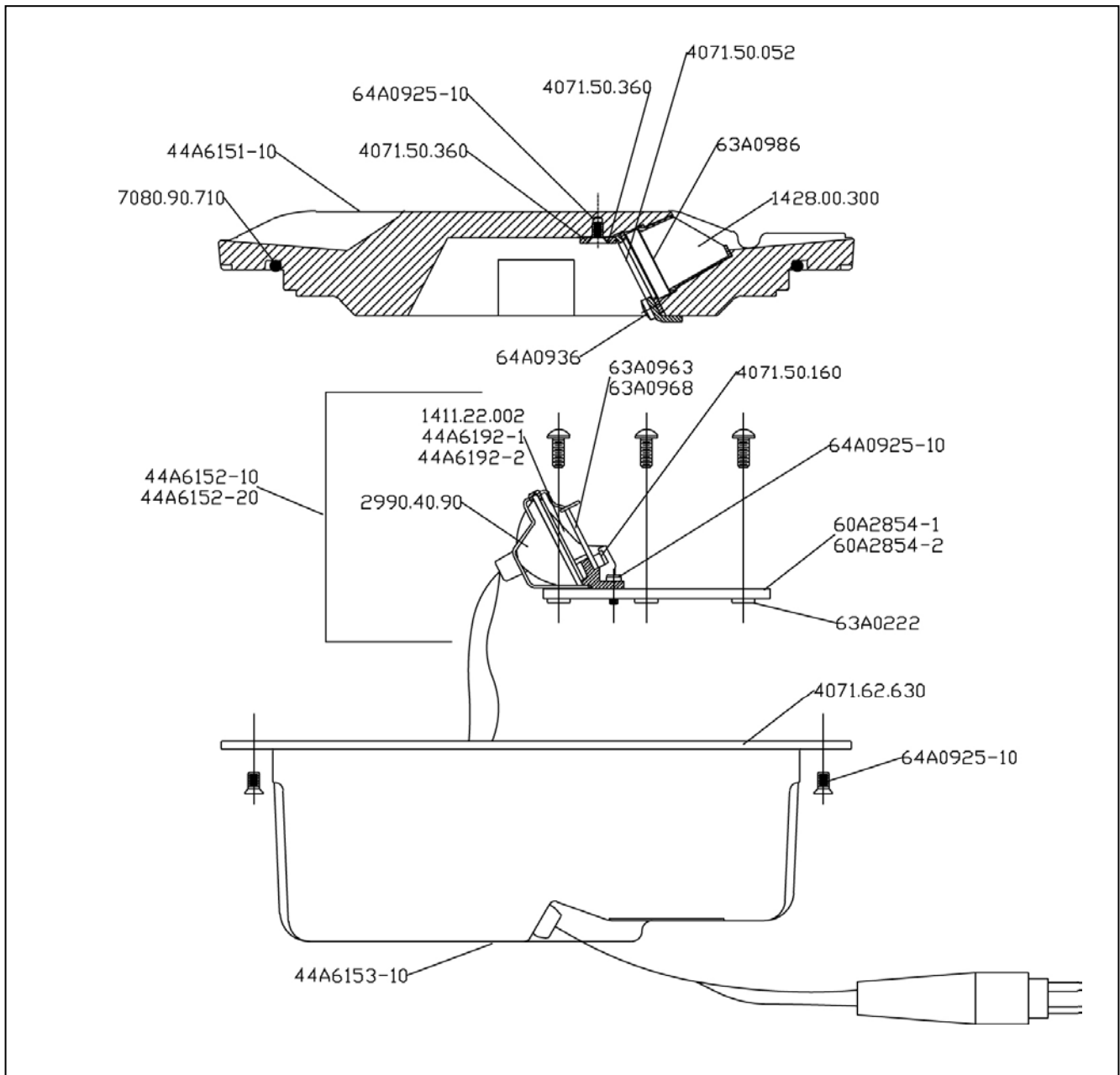

Figure 7-2 F-Range High Intensity Style 2 Approach Light (1 of 3)

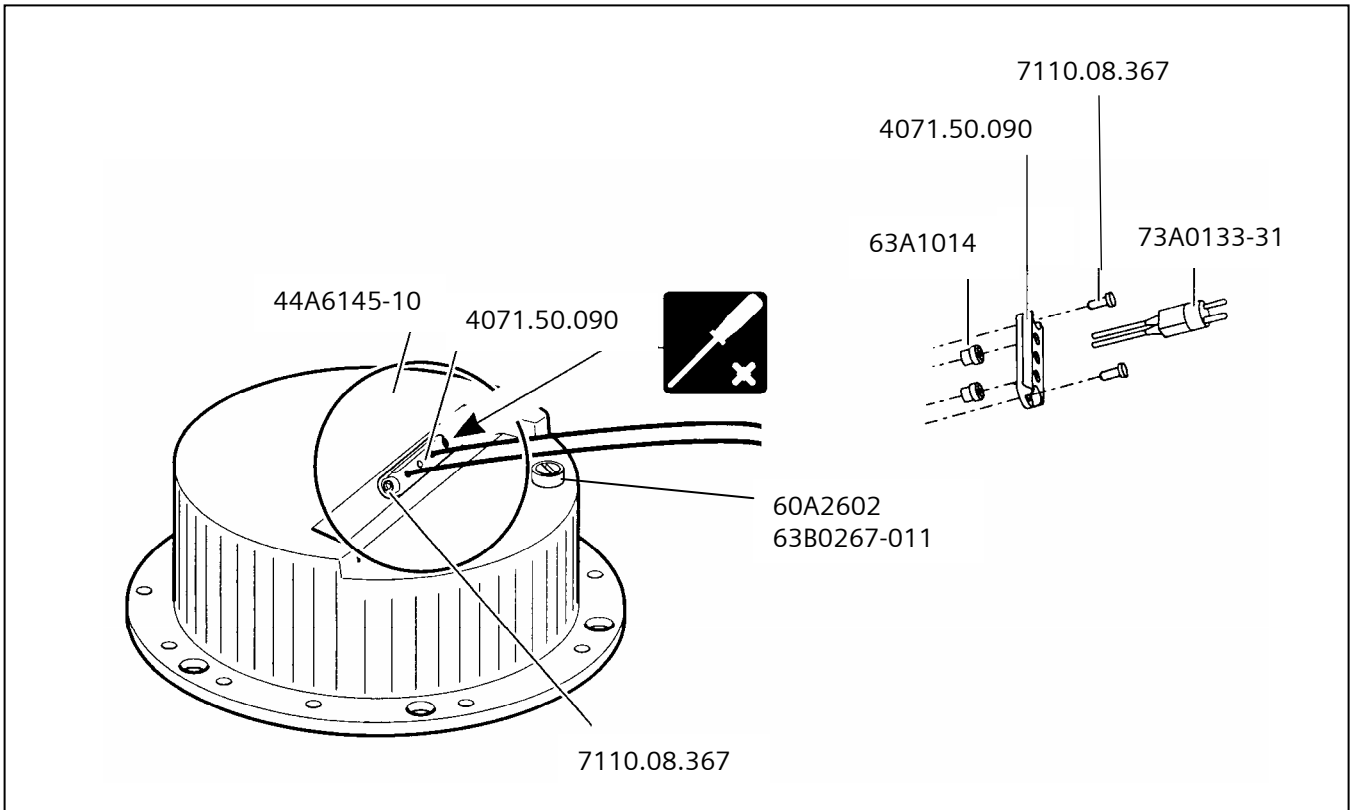

Figure 7-2. F-Range High Intensity Style 2 Approach Light (2 of 3)

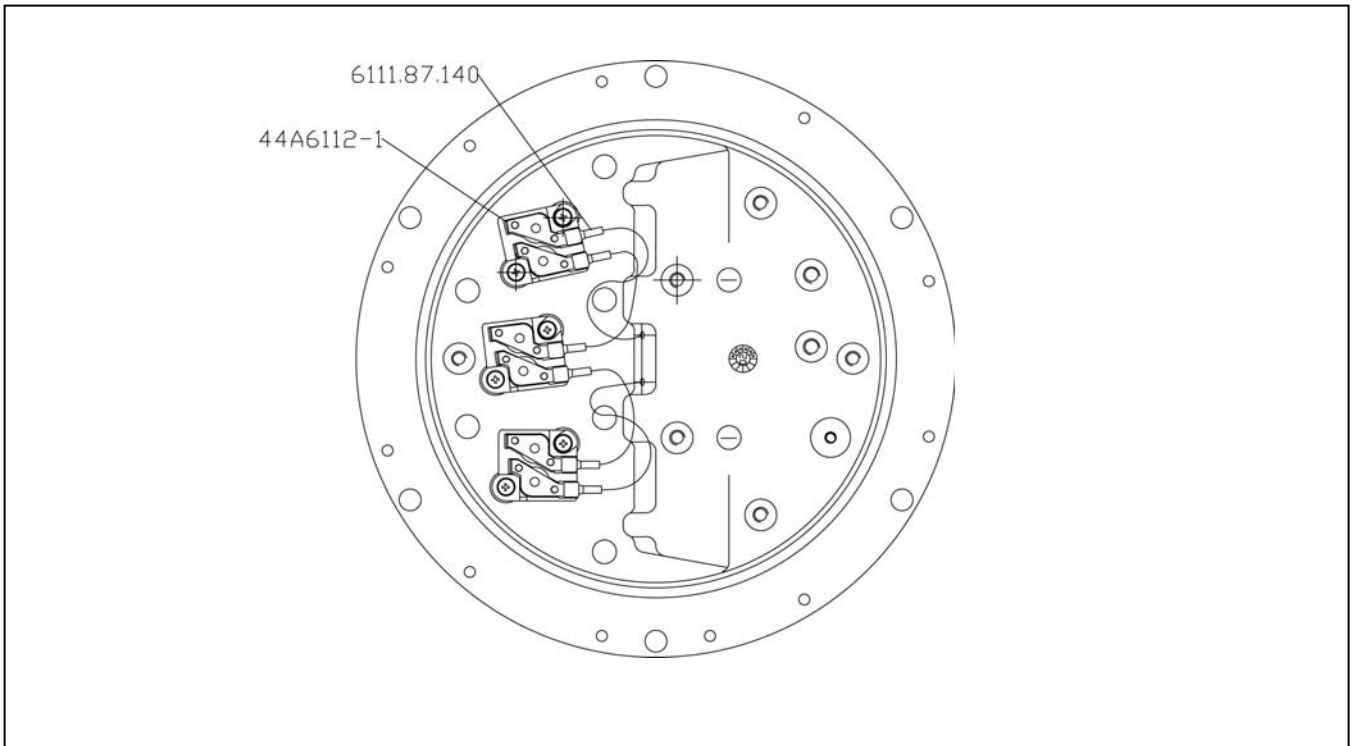

Figure 7-2. F-Range High Intensity Style 2 Approach Light (3 of 3)

5. F-Range Optical Unit Parts List

See Figure 7-2.

Part Number	Description	Quantity	Note
44A6152-10	Optical unit (for red or green filters)	1	
44A6152-20	Optical unit (for no filters)	1	
44A6192-1	Modified lamp holder assembly, right-hand	See note.	A
44A6192-2	Modified lamp holder assembly, left-hand	See note.	B
60A2854-1	Optical support bracket (for red or green filter)	1	
60A2854-2	Optical support bracket (for no filter)	1	
63A0222	Grommet (for optical bracket)	5	
1411.22.002	Lamp and filter holder assembly	See note.	C
2990.40.900	Lamp, 105 W	3	
7110.08.367	Screw, M4 x 10 (for optical bracket)	3	
7284.10.416	Spring lockwasher, M4	3	
NOTE A: Quantity is 1 for the modified lamp holder assembly right-hand for the 44A6152-20 optical support assembly. See also Figure 6-5 in Section 6, <i>Repairs</i> .			
NOTE B: Quantity is 1 for the modified lamp holder assembly left-hand for the 44A6152-20 optical support assembly. See also Figure 6-5 in Section 6, <i>Repairs</i> .			
NOTE C: Quantity is 1 for the 44A6152-20 optical support assembly. Quantity is 3 for the 44A6152-10 optical support assembly.			

6. Recommended Spare Parts

See Figure 7-2.

Part Number	Description
44A6112-1	Terminal block assembly (without film disc cutout)
44A6143	Optional lamp shorting device
44A6151-10	Top cover
44A6152-10	Optical unit (for red or green filters)
44A6152-20	Optical unit (for no filters)
44A6153-10	Inner pan assembly
44A6192-1	Modified lamp holder assembly, right-hand
44A6192-2	Modified lamp holder assembly, left-hand
60A2602	Pressure release screw
60A2854-1	Optical support bracket (red or green)
60A2854-2	Optical support bracket (white)
63A1014	Grommets (for cordset)
63A0222	Grommet (for optical bracket)
63A0963	Filter, green
63A0968	Filter, red
63A0986	Flat seal
63B0267-011	O-ring, pressure screw
64A0925-10	Screw, M5 x 10 Screw, M5 x 10 (for top cover assembly) Screw, M5 x 10 (to connect top cover assembly to inner pan assembly)
64A0936-13	Screw, M5 x 13 (for top cover assembly)
73A0133-31	Cordset

Continued on next page

6. Recommended Spare**Parts** (contd.)

Part Number	Description
1411.22.002	Lamp and filter holder assembly
1428.00.300	Prism, narrow beam, optical glass
2990.40.900	Lamp, 105 W
4071.50.030	Sock seal
4071.50.052	Prism keeper plate
4071.50.090	Wire clamp (for cordset)
4071.50.160	Filter spring
4017.50.360	Prism clamp
4071.62.630	Inner cover
6111.87.140	Fast-on connector (for inner pan terminal block)
7080.90.710	O-ring (for top cover)
7110.08.367	Screw, M4 x 10
	Screw, M4 x 10 (for optical bracket)
	Screw, M4 x 10 (for cordset)
7284.10.416	Spring lockwasher, M4