



Ferroresonant L-828 Constant Current Regulator with Universal Regulator Controller (URC) Oil-Filled 50–70 kVA/20 A

Document No. 96A0290

Issued: February 1, 2002

Rev. A: February 1, 2002

ETL Certified to FAA Specification
AC 150/5345-10E

Siemens Airfield Solutions, Inc.

P.O. Box 30829
977 Gahanna Parkway
Columbus, OH 43230

Tel: (614) 861-1304
Fax: (614) 864-2069

Copyright © 2002 by Siemens Airfield Solutions, Incorporated. All rights reserved.

Siemens Airfield Solutions

*The innovative
approach*

Table of Contents

Record of Changesii
 Table of Contentsiii
 Warrantiesvi

Safety

Section 1 Safety..... 1-2
 1. Introduction 1-2
 2. Safety Symbols 1-3
 3. Qualified Personnel 1-3
 4. Intended Use 1-4
 5. Installation 1-4
 6. Operation 1-5
 7. Action in the Event of a System or Component Malfunction..... 1-6
 8. Maintenance and Repair 1-6

Description

Section 2 Description..... 2-1
 1. Introduction 2-1
 2. Universal Regulator Controller..... 2-2
 3. Theory of Operation 2-3
 Power Circuit 2-3
 Output Measurement 2-4
 Universal Regulator Controller..... 2-4
 4. Ferroresonant L-828 CCRs (50 and 70 kVA/ 20 A):
 Required Equipment..... 2-7
 5. Specifications 2-8
 Ratings 2-8
 Class..... 2-8
 Construction..... 2-8
 Style..... 2-8
 Power Factor 2-8
 Efficiency..... 2-8
 Reactive Loading..... 2-8
 Oil Tank Capacity 2-8
 Resistive Loading 2-9
 Environmental Operating Conditions..... 2-9
 Protection Devices 2-9
 Input Current..... 2-10
 Input Voltage..... 2-10
 Built-In True RMS-Reading Ammeter 2-10
 Rating and Input Voltage..... 2-11
 Weight 2-11
 Dimensions 2-11

Installation	Section 3 Installation 3-1
	1. Introduction 3-1
	2. Unpacking 3-1
	3. Installation 3-1
	Wiring Connections and Startup 3-2
Operation	Section 4 Operation 4-1
	1. Introduction 4-1
	2. Control Procedures 4-1
	Local Control 4-1
	Remote Control 4-2
	3. Shutdown Procedure 4-2
	4. Adjustment Procedures 4-3
	Output Current Adjustment 4-3
	Overcurrent Adjustment 4-4
Maintenance	Section 5 Maintenance 5-1
	1. Introduction 5-1
	2. Maintenance Schedule 5-1
	Short-Circuit Test 5-3
	Open-Circuit Test 5-3
	Oil Removal and Replacement 5-4
Troubleshooting	Section 6 Troubleshooting 6-1
	1. Introduction 6-1
	2. Preliminary Troubleshooting 6-2
	3. Troubleshooting Fuses 6-2
	Input Power Fuses F1 and F2 6-2
	Step-Up/Down Transformer T3 Fuses F3 and F4 Universal Regulator Power Supply Transformer Fuses F5 and F6 6-3
	4. General Troubleshooting Procedures 6-3
Parts	Section 7 Parts 7-1
	1. Introduction 7-1
	2. Using the Illustrated Parts List 7-1
	3. L-828 CCR (50 and 70 kVA/20 A) Part Numbering System 7-2
	4. L-828 CCR General Assembly (50/70 kVA/480 and 2400 Vac/20 A) Parts List 7-2
	5. Recommended Spare Parts 7-4
Wiring Schematics	Section 8 Wiring Schematics 8-1
	1. Introduction 8-1
	2. Wiring Schematics 8-1

List of Figures

Figure 2-1 Ferroresonant L-828 CCR (50 kVA/20 A)	2-1
Figure 2-2 L-828 CCR Power Circuit Block Diagram	2-3
Figure 2-3 URC Board	2-4
Figure 4-1 Switch (5-Step)	4-1
Figure 4-2 R40 on URC Board (1)	4-4
Figure 8-1 L-828 CCR with URC (50 and 70 KVA) Internal Wiring Schematic (Part 1 of 2)	8-2

List of Tables

Table 2-1 Required Equipment Supplied	2-7
Table 2-2 Required Equipment Not Supplied	2-7
Table 2-3 Recommended Input Wiring Rating	2-7
Table 2-4 Style	2-8
Table 2-5 Current Range for 5-Step 20 A CCR	2-8
Table 2-6 Recommended L-828 CCR Input Current	2-10
Table 2-7 Rating and Input Voltage	2-11
Table 2-8 Weight	2-11
Table 2-9 Dimensions	2-11
Table 3-1 Remote Control Connections (5-Step/20 A)	3-3
Table 4-1 Output Current from Rotary Switch Positions for Local Control (5-Step/20 A)	4-2
Table 4-2 Remote Control	4-2
Table 5-1 L-828 CCR (50 and 70 kVA/20 A) Maintenance	5-1
Table 6-1 CCR Input Voltage and CCR kVA Rating for Input Power Fuses F1 and F2	6-2
Table 6-2 Transformer T3 Fuses F3 and F4 Ratings	6-3
Table 7-1 L-828 CCR (50 and 70 kVA/20 A) Part Numbers	7-2

Warranties

Products of Siemens Airfield Solutions manufacture are guaranteed against mechanical, electrical, and physical defects (excluding lamps) for a period of one year from the date of installation or a maximum of two years from the date of shipment and are guaranteed to be merchantable and fit for the ordinary purposes for which such products are made.

Siemens Airfield Solutions will correct by repair or replacement, at its option, equipment or parts which fail because of mechanical, electrical or physical defects, provided that the goods have been properly handled and stored prior to installation, properly installed and properly operated after installation, and provided further that Buyer gives Siemens Airfield Solutions written notice of such defects after delivery of the goods to Buyer.

Siemens Airfield Solutions reserves the right to examine goods upon which a claim is made. Said goods must be presented in the same condition as when the defect therein was discovered. Siemens Airfield Solutions further reserves the right to require the return of such goods to establish any claim.

Siemens Airfield Solutions's obligation under this guarantee is limited to making repair or replacement within a reasonable time after receipt of such written notice and does not include any other costs such as the cost of removal of defective part, installation of repaired product, labor or consequential damages of any kind, the exclusive remedy being to require such new parts to be furnished.

Siemens Airfield Solutions's liability under no circumstances will exceed the contract price of goods claimed to be defective. Any returns under this guarantee are to be on a transportation charges prepaid basis. For products not manufactured by, but sold by Siemens Airfield Solutions, warranty is limited to that extended by the original manufacturer.

This is Siemens Airfield Solutions's sole guarantee and warranty with respect to the goods; there are no express warranties or warranties of fitness for any particular purpose or any implied warranties of fitness for any particular purpose or any implied warranties other than those made expressly herein. All such warranties being expressly disclaimed.

Disclaimers

This manual could contain technical inaccuracies or typographical errors. Siemens Airfield Solutions reserves the right to revise this manual from time to time in the contents thereof without obligation of Siemens Airfield Solutions to notify any person of such revision or change.

Details and values given in this manual are average values and have been compiled with care. They are not binding, however, and Siemens Airfield Solutions disclaims any liability for damages or detriments suffered as a result of reliance on the information given herein or the use of products, processes or equipment to which this manual refers. No warranty is made that the use of the information or of the products, processes or equipment to which this manual refers will not infringe any third party's patents or rights. The information given does not release the buyer from making their own experiments and tests.

Section 1

Safety

1. Introduction

This section contains general safety instructions for using your Siemens Airfield Solutions equipment. Some safety instructions may not apply to the equipment in this manual. Task- and equipment-specific warnings are included in other sections of this manual where appropriate. Note all warnings and follow all instructions carefully. Failure to do so may result in personal injury, death, or property damage.

To use this equipment safely,

- refer to the FAA Advisory Circular AC 150/5340-26, *Maintenance of Airport Visual Aids Facilities*, for instructions on safety precautions.
- observe all safety regulations. To avoid injuries, always remove power prior to making any wire connections and touching any parts. Refer to FAA Advisory Circular AC 150/5340-26.
- read and become familiar with the general safety instructions provided in this section of the manual before installing, operating, maintaining, or repairing this equipment.
- read and carefully follow the instructions given throughout this manual for performing specific tasks and working with specific equipment.
- store this manual within easy reach of personnel installing, operating, maintaining, or repairing this equipment.
- follow all applicable safety procedures required by your company, industry standards, and government or other regulatory agencies.
- obtain and read Material Safety Data Sheets (MSDS) for all materials used.

2. Safety Symbols

Become familiar with the safety symbols presented in this section. These symbols will alert you to safety hazards and conditions that may result in personal injury, death, or property and equipment damage.



WARNING: Failure to observe this warning may result in personal injury, death, or equipment damage.



WARNING: Risk of electrical shock. Failure to observe this warning may result in personal injury, death, or equipment damage.



WARNING: Disconnect equipment from line voltage. Failure to observe this warning may result in personal injury, death, or equipment damage.



WARNING: Wear safety goggles. Failure to observe may result in serious injury.



CAUTION: Failure to observe may result in equipment damage.



CAUTION: Contents are static-sensitive. Must be grounded when handling PCBs.

CONTENTS
STATIC-SENSITIVE
MUST BE GROUNDED
WHEN HANDLING PCB

3. Qualified Personnel

The term *qualified personnel* is defined here as individuals who thoroughly understand the equipment and its safe operation, maintenance, and repair. Qualified personnel are physically capable of performing the required tasks, familiar with all relevant safety rules and regulations and have been trained to safely install, operate, maintain, and repair the equipment. It is the responsibility of the company operating this equipment to see that its personnel meet these requirements.

4. Intended Use



WARNING: Use of this equipment in ways other than described in this manual may result in personal injury, death, or property and equipment damage. Use this equipment only as described in this manual.

Siemens Airfield Solutions cannot be responsible for injuries or damages resulting from nonstandard, unintended applications of its equipment. This equipment is designed and intended only for the purpose described in this manual. Uses not described in this manual are considered unintended uses and may result in serious personal injury, death, or property damage. Unintended uses may result from taking the following actions:

- making changes to equipment that have not been recommended or described in this manual or using parts that are not genuine Siemens Airfield Solutions replacement parts
- failing to make sure that auxiliary equipment complies with approval agency requirements, local codes, and all applicable safety standards
- using materials or auxiliary equipment that are inappropriate or incompatible with your Siemens Airfield Solutions equipment
- allowing unqualified personnel to perform any task

5. Installation

Read the installation section of all system component manuals before installing your equipment. A thorough understanding of system components and their requirements will help you install the system safely and efficiently.



WARNING: Failure to follow these safety procedures can result in personal injury or death.

- Allow only qualified personnel to install Siemens Airfield Solutions and auxiliary equipment. Use only approved equipment. Using unapproved equipment in an approved system may void agency approvals.
- Make sure all equipment is rated and approved for the environment in which you are using it.
- Follow all instructions for installing components and accessories.
- Install all electrical connections to local code.

5. Installation *(contd.)*

- Use only electrical wire of sufficient gauge and insulation to handle the rated current demand. All wiring must meet local codes.
- Route electrical wiring along a protected path. Make sure they will not be damaged by moving equipment.
- Protect components from damage, wear, and harsh environment conditions.
- Allow ample room for maintenance, panel accessibility, and cover removal.
- Protect equipment with safety devices as specified by applicable safety regulations.
- If safety devices must be removed for installation, install them immediately after the work is completed and check them for proper functioning.

6. Operation

Only qualified personnel, physically capable of operating the equipment and with no impairments in their judgment or reaction times, should operate this equipment.

Read all system component manuals before operating this equipment. A thorough understanding of system components and their operation will help you operate the system safely and efficiently.

- Before starting this equipment, check all safety interlocks, fire-detection systems, and protective devices such as panels and covers. Make sure all devices are fully functional. Do not operate the system if these devices are not working properly. Do not deactivate or bypass automatic safety interlocks or locked-out electrical disconnects or pneumatic valves.
- Never operate equipment with a known malfunction.
- Do not attempt to operate or service electrical equipment if standing water is present.
- Use this equipment only in the environments for which it is rated. Do not operate this equipment in humid, flammable, or explosive environments unless it has been rated for safe operation in these environments.
- Never touch exposed electrical connections on equipment while the power is ON.

7. Action in the Event of a System or Component Malfunction

Do not operate a system that contains malfunctioning components. If a component malfunctions, turn the system OFF immediately.

- Disconnect and lock out electrical power.
- Allow only qualified personnel to make repairs. Repair or replace the malfunctioning component according to instructions provided in its manual.

8. Maintenance and Repair

Allow only qualified personnel to perform maintenance, troubleshooting, and repair tasks. Only persons who are properly trained and familiar with Siemens Airfield Solutions equipment are permitted to service this equipment.

- Always use safety devices when working on this equipment.
- Follow the recommended maintenance procedures in your equipment manuals.
- Do not service or adjust any equipment unless another person trained in first aid and CPR is present.
- Connect all disconnected equipment ground cables and wires after servicing equipment. Ground all conductive equipment.
- Use only approved Siemens Airfield Solutions replacement parts. Using unapproved parts or making unapproved modifications to equipment may void agency approvals and create safety hazards.
- Check interlock systems periodically to ensure their effectiveness.
- Do not attempt to service electrical equipment if standing water is present. Use caution when servicing electrical equipment in a high-humidity environment.
- Use tools with insulated handles when working with electrical equipment.

Section 2

Description

1. Introduction

See Figure 2-1. This section describes the Siemens Airfield Solutions ferroresonant oil-cooled L-828 constant current regulators (CCRs) (50 and 70 kVA/20 A). These CCRs are manufactured according to FAA specification AC 150/5345-10E.

NOTE: Figure 2-1 shows an oil-cooled ferroresonant L-828 CCR (50 kVA/20 A) CCR. The 70 kVA/20 A oil-cooled L-828 CCR may differ in size and appearance.



Figure 2-1 Ferroresonant L-828 CCR (50 kVA/20 A)

1. Introduction *(contd.)*

The L-828 CCRs are designed to

- supply five precision output current levels (20 A maximum) to power airport series lighting circuits on runways and taxiways.
- accurately regulate the output current to within $\pm 1\%$ of the adjustable nominal levels from no load to full load and with input voltage variations of -5% to +10% of nominal.
- maintain the nominal output current levels even when 30 percent of the isolation transformers in the series lighting circuit supplied by the regulator have open secondaries

2. Universal Regulator Controller

The Universal Regulator Controller (URC) is designed to provide all regulator and control functions for ferroresonant L-828 CCRs manufactured by Siemens Airfield Solutions. This is accomplished with an 8-bit embedded microcontroller and interface circuitry contained on a single 8 x 8 inch through-hole type printed circuit board. The universal regulator controller PCB performs the functions listed below.

- Produces SCR drive signals in accordance with the signals from the input module PCB
- Detects an overcurrent, open circuit, and switches the constant current regulator off
- When in Remote mode, enables CCI to provide 120 Vac at 50 W

3. Theory of Operation

This subsection describes the L-828 CCR theory of operation.

Power Circuit

See Figure 2-2. A resonant network T1 and C1-CX feeds the output circuit independent of the impedance of the load with a current proportional to the value of the input voltage. Control and regulation of the output current is accomplished by the SCRs shunting a part of the resonant circuit, and thus decreasing the output current. The components of the resonant network are designed to deliver an output current slightly higher than 20 A for the minimum input voltage, while the SCRs are in the OFF state.

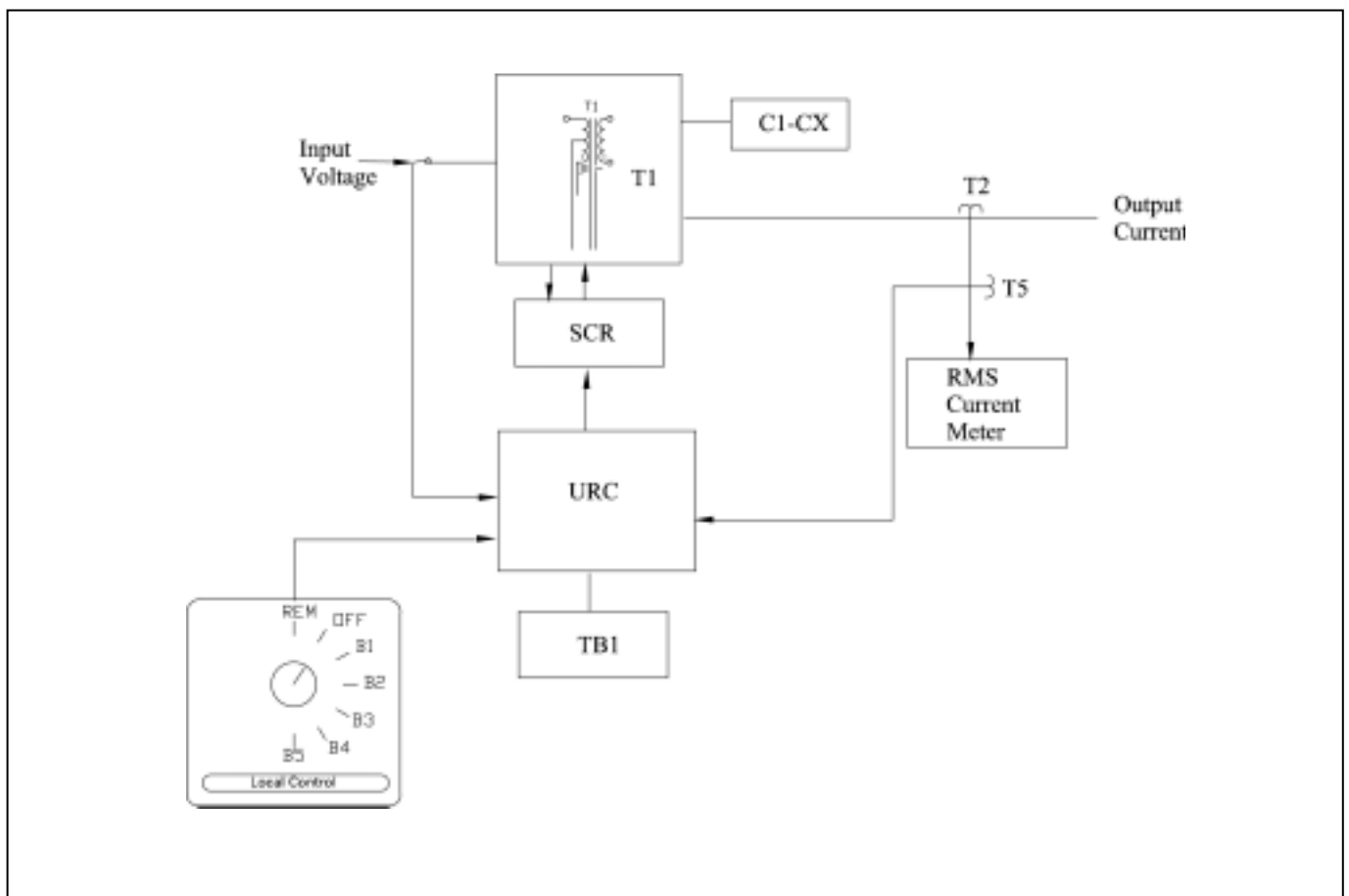

Figure 2-2 L-828 CCR Power Circuit Block Diagram

Output Measurement

The output current flows through the high voltage current transformer T2. T2 steps the output current down to a maximum of 6.6 A to drive the true rms-reading current meter and feedback transformer T5. The secondary of transformer T5 delivers a nominal current of .066 A to the current regulator control circuitry.

Universal Regulator Controller

See Figure 2-3. This subsection describes the board level circuitry found on the universal regulator controller.

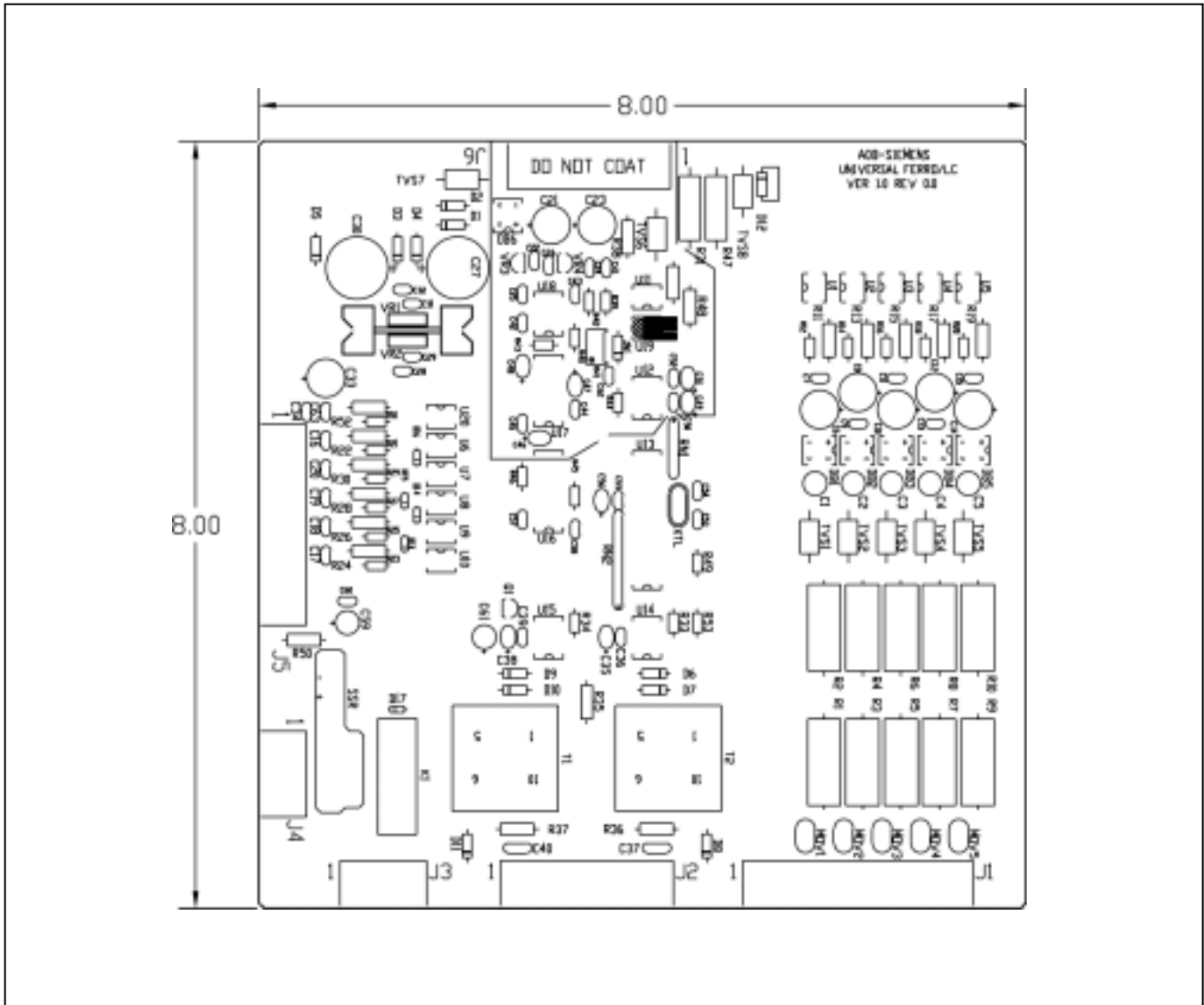

Figure 2-3 URC Board

URC PCB Inputs/Outputs

The URC receives the inputs listed below. See Figure 7-3 in the *Parts* section and Figure 8-1 in the *Wiring Schematics* section.

- Local control signals from the front panel rotary switch (J5-1 through J5-7)
- Remote control signals from a remote control terminal block located in the L-828 chassis (120 Vac) (TB1) (J1)
- A current proportional to the output current from a current transformer (T5) (J6-3 and J6-4)
- Phase angle reference voltage (pins J6-1 and J6-2)
- 24 Vac center tapped supply voltage (J6-6 through J6-8)

The URC provides the outputs listed below.

- A contact to complete the input contactor coil circuit (J4-1 and J4-3)
- A contact to enable the Remote CCI voltage at TB1 (J3-1 and J3-3)
- Gate drive signals to the SCR block used to regulate the output current
- Jumper point to select a 3-Step regulator (J5-8 and J5-9)
- Jumper point to enable ferroresonant control (J5-9 and J5-10)

Output Current Monitor Circuitry

The system output current is sensed by a current transformer (T5) whose secondary is connected to J6-4 and J6-3. This current signal is passed through a 15-ohm shunt resistor (R38), located on the URC board. For the 6.6 amp regulator a /100 scale factor is used. Output current steps 1-5 correspond to voltage levels of 420, 510, 615, 780, and 990 millivolts respectively. On a 20 A regulator, T2 steps the current by an additional factor of 3. This allows the URC Board to operate at the same feedback level for Class 2 (20 A) regulators.

Local Control Position Detection

Local control position detection is accomplished by using a rotary switch (external to the control board) to connect the cathode of an opto-isolator to ground causing the output transistor of the same isolator to turn on and pull the corresponding step signal to ground. This allows the URC board to operate at the same feedback level for Class 2 level (20 A) regulators. This signal is monitored by the micro-controller to determine the local step. There are signal diodes connected from each step back to step one. This allows step one system on to be provided to the micro-controller whenever the step switch is in any position other than remote or off.

Universal Regulator Controller *(contd.)*

Contactor Drive

The contactor drive circuit is provided on J4-1 and J4-3 to complete the circuit that powers the input contactor for the regulator. This may be either 110 or 240 Vac, depending on the input voltage to the system.

Remote Control Position Detection

When the local control signal to the micro-controller indicates "remote" the remote position detection circuitry is active. Relay K1 on the URC Board closes, providing 120VAC to the CCI connection on TB2. The remote position detection section is composed of input surge suppression, attenuation, a bridge rectifier and an opto-isolator for each step that together provide remote step signals to the micro-controller.

Failure Protection

This subsection describes URC failure protection.

Overcurrent Protection

The micro-controller detects an over current condition by comparing the output current to a preset value. If the output current exceeds this value the controller will shut the current regulator down by removing drive to the input contactor. This contactor will remain de-energized until the controller is reset either by selecting the OFF position (remotely or locally) or cycling the input power off for a minimum of 2 seconds and then back on. The control board will not recognize momentary over currents caused by load switching or other transient conditions.

Open Circuit Protection

The micro-controller detects an open circuit by the absence of current in the regulator output (this will also detect an open or shorted current feedback transformer). If the output current is less than 1.5 amps, the controller will shut the current regulator down within one second by removing drive to the input contactor. This contactor will remain de-energized until the controller is reset either by selecting the OFF position (remotely or locally) or cycling the input power off for a minimum of 2 seconds and then back on.

4. Ferroresonant L-828 CCRs (50 and 70 kVA/ 20 A): Required Equipment

Refer to Table 2-1 for required equipment that is supplied. Refer to Table 2-2 for required equipment that is not supplied. Refer to the *Parts* section for ordering information.

Table 2-1 Required Equipment Supplied

Description	Quantity
L-828 constant current regulator	1
Instruction manual	1 per order

Table 2-2 Required Equipment Not Supplied

Description	Quantity
Input power wire. Refer to Table 2-3.	As required
Remote control wire, AWG 19 minimum, AWG 14 maximum	As required
Ground wire, AWG 6 minimum	As required
Output load wire, AWG 8 minimum, 5000 Vac, L-824 type	As required
Shorting jumper wire, AWG 8 minimum	As required
Disconnect switch or main circuit breaker	1
DVM Fluke 87 or equivalent	1
Current clamp (for DVM Fluke 87 or equivalent)	1

NOTE: Table 2-3 refers to recommended input power supply wire, 90 °C, 600 or 5000 V minimum

Table 2-3 Recommended Input Wiring Rating

kVA Rating	480 Vac	2400 Vac
50 kVA	1 AWG, 600 V	8 AWG, 5000 V
70 kVA	2/0 AWG, 600 V	8 AWG, 5000 V

5. Specifications

This subsection provides specifications for L-828 CCR (50 and 70 kVA/20 A) oil-cooled CCRs with URC board.

Ratings

50 kVA and 70 kVA

Class

Class 2 (20 A maximum output current)

Construction

A painted steel-top cabinet and bottom oil tank. The URC Board and associated hardware inside the top cabinet is connected to the regulator by plug-in connectors. The oil tank contains the cooling tank and all the power components: the power transformer and capacitors. An oil drain plug/sampling valve is provided on the bottom rear of the oil tank, and an oil gauge is provided to indicate the oil level in the tank.

Style

Refer to Table 2-4.

Table 2-4 Style

Class	Style	Brightness Steps	Current
2	2	5	8.5 A, 10.3 A, 12.4 A, 15.8 A, 20 A

Power Factor

95 percent minimum

Efficiency

93 percent minimum

Reactive Loading

The CCRs maintain the current within the limits of Table 2-5 for all brightness steps when the load is connected via isolating transformers, and the secondaries of 30% of these transformers become open-circuited. The load before opening the isolation transformer secondaries may be any value from half to full load

Table 2-5 Current Range for 5-Step 20 A CCR

Step	Nominal Output Current	Allowable Current Range
1	8.5 A	8.24-8.76 A
2	10.3 A	9.99-10.61 A
3	12.4 A	12.03-12.77 A
4	15.8 A	15.33-16.27 A
5	20 A	19.40-20.30 A

Oil Tank Capacity

160 gallons (605.7 liters) (Shell Diala AX or Texaco #5) for 50 kVA only

Resistive Loading

The CCRs maintain the output current within the limits of Table 2-6 while powering any load between no load or short circuit and full load. The regulation is maintained over the full range of environmental conditions specified in this section and for the input voltages specified above.

Environmental Operating Conditions

The L-828 CCRs (50 and 70 kVA/20 A) are designed for indoor use only in an area with adequate ventilation for cooling the constant current regulator. The environmental operating conditions include temperature range, relative humidity, and altitude.

Temperature Range

-40 to +55 °C (-40 to +131 °F)

Relative Humidity

10 to 100% (noncondensing)

Altitude

Sea level to 6,600 ft (2000 m)

Protection Devices

L-828 CCRs have the following protection devices:

- Output open-circuit protection.
- Output overcurrent protection.
- Lightning arrestors on output terminals and bushings.

NOTE: Input lightning protection can be ordered as an option for 480 and less input voltages.

- Fuse protection of AC supply voltage of the URC PCB and brightness control voltage for Remote control

Open-Circuit Protection

The primary power contactor is opened in less than 1 second after an open circuit occurs in the secondary. The open-circuit protective device is reset within 2 seconds after the rotary selector switch on the CCR is turned to OFF (or the CCR is turned OFF while it is in remote control) and re-energized, and is not tripped by switching of load circuits or other transients.

Overcurrent Protection

The primary power contactor is opened when the output current exceed 20 A by 5%. The device operates within 5 seconds after an overcurrent of 5% and within 1 second after an overcurrent of 25%. The device is reset within 2 seconds after the rotary selector switch on the CCR is turned to OFF (or the CCR is turned OFF while it is in remote control). The overcurrent protection is not activated by a momentary (0.25s) overcurrent caused by switching of load circuits or other transients.

Input Current

Refer to Table 2-6.

NOTE: It is recommended that the circuit breaker on the input power supply lines have a rating of 125% of the CCR's input current as shown on Table 2-6, unless local codes require a different rating technique. Refer to the CCR's nameplate for the kVA rating and input voltage to determine the input current on Table 2-7. If no standard-size circuit breaker exists at the 125% value, use the next larger standard-size circuit breaker.

Table 2-6 Recommended L-828 CCR Input Current

KVA Rating	480 Vac	2400 Vac
50 kVA	120 A	25 A
70 kVA	170 A	35 A

Input Voltage

The power transformer for the L-828 regulators is designed for an input voltage of either 480 or 2400 Vac. The input voltage must be accurately determined prior to ordering the regulator because no alternate input voltage tapes are available.

Built-In True RMS-Reading Ammeter

A true rms-reading ammeter mounted on the panel of the CCR indicates the output current. The screw on the face of the ammeter is for zeroing the indicator needle.

Rating and Input Voltage

Refer to Table 2-7.

Table 2-7 Rating and Input Voltage

Rating	Input Voltage
50 kVA	480 (-5% to +10%)
70 kVA	2400 (-5% to +10%)

Weight

Refer to Table 2-8 for weight of all L-828 CCRs with URC.

Table 2-8 Weight

Rating and Input Voltage	Weight lb (kg) (Approximate)
50 kVA (480 Vac)	3360 (1524)
50 kVA (2400 Vac)	3460 (1569)
70 kVA (480 Vac)	3460 (1569)
70 kVA (2400 Vac)	3460 (1569)

Dimensions

Refer to Table 2-9.

Table 2-9 Dimensions

Rating and Input Voltage	Dimension (Height x Width x Depth) (Approximate)
50 kVA (480 Vac)	74.25 x 38.00 x 39.40 (1886 x 965 x 1001 mm)
50 kVA (2400 Vac)	74.25 x 38.00 x 39.40 (1886 x 965 x 1001 mm)
70 kVA (480 Vac)	74.25 x 38.00 x 39.40 (1886 x 965 x 1001 mm)
70 kVA (2400 Vac)	74.25 x 38.00 x 39.40 (1886 x 965 x 1001 mm)

Section 3

Installation



WARNING: Allow only qualified personnel to perform the following tasks. Observe and follow the safety instructions in this document and all other related documentation.



WARNING: Contents are static-sensitive. Must be grounded when handling PCB.

1. Introduction

This section provides instructions for installing an oil-cooled L-828 constant current regulators (CCRs) (50 and 70 kVA/20 A). Refer to the airport project plans and specifications for the specific installation instructions and FAA AC 150/5345-10E.

2. Unpacking

The equipment is shipped ready for installation. Handle equipment very carefully to prevent component damage. Unpack the carton upon receipt and check the contents and their condition. Note any exterior damage to the carton that might lead to detection of equipment damage.

If you note any damage to any equipment, file a claim with the carrier immediately. The carrier may need to inspect the equipment.

NOTE: Take care to maintain the unit in an upright position when handling the regulator.

3. Installation

This section describes installation procedures.

The regulator can be lifted using a forklift or gantry crane using the four eyebolts on the tank. Place the regulator inside a well ventilated room with sufficient clearance for personnel to inspect and maintain the regulator. Level the regulator so that a tank is not more than 5 degrees off of vertical.

Four 0.55 x 1.40 inch (13.97 x 35.56 mm) slotted holes are provided on the mounting channels of the regulator for bolting the CCR to the floor or rail. Use four (1/2–16 x 1 1/2 inch long) mounting bolts, (1/2 STD) washers and lock washers.

Check the oil gauge. The oil level at 20°C, a corresponding increase or decrease will occur in oil volume. The oil-level reading will be high if the regulator is at operating temperatures or low if shut off and the ambient temperature is below 20°C.

Wiring Connections and Startup



WARNING: Installation and operation of the CCR should be performed by personnel qualified to work on high voltage equipment. The high voltage involved with the unit makes it potentially dangerous and may be lethal if contacted by operating personnel.

To install wiring, perform the following procedure:

1. Verify the input supply voltage corresponds to the voltage rating on the nameplate of the regulator.
2. Make sure the front panel rotary selector switch is set to the OFF position.
3. Ground the regulator by making an adequate ground wire (AWG 6 or larger) connection to the external earth ground lug on the regulator.
4. An appropriate disconnect-type cutout or circuit breaker shall be provided outside the regulator for the input power supply lines.
5. Short-circuit the output terminals TB2-1 and TB2-2 bushings E1, E2 using AWG minimum wire to avoid lamp destruction in case of excessive current output.
6. Install appropriate external lightning arrestors on the input power supply lines as close as possible to the CCR's input or terminal block TB3-1 and TB3-2.
7. Refer to Table 2-3 for the recommended input wire. Connect the power supply lines from the disconnect switch or main circuit breaker to the CCR input terminal block TB3-1 and TB3-2. Tighten all connections.
8. Engage main circuit breaker or disconnect switch to energize the regulator.
9. Turn the front panel rotary selector switch to all brightness steps, and verify that current values on the panel ammeter correspond to those in Table 2-6.
10. Turn the rotary selector switch to OFF.
11. Disengage the main current breaker or disconnect switch to de-energize the regulator.

Wiring Connections and Startup *(contd.)*

12. Connect remote control lines, if required, to remote control terminal block TB1. Use AWG 19, 300 V wire or larger as indicated in Table 3-1 for 120 Vac signals. See Figure 8-1 in the *Wiring Schematics* section for remote control connections.

NOTE: Table 3-1 provides the necessary connections for remote control. Terminal B1 does not need to be wired. Brightness step B1 occurs when the regulator is switched on.

NOTE: In Table 3-1, if more than one intensity step is energized, the CCR will operate on the highest command step.

Table 3-1 Remote Control Connections (5-Step/20 A)

For this remote intensity step...	Connect CCI to...
8.5 A	CC
10.3 A	CC, B2
12.4 A	CC, B3
15.8 A	CC, B4
20 A	CC, B5
OFF	Nothing

13. Make sure wiring connections are tight and no wires are shorting across each other.

NOTE: If more than one intensity step is energized, the CCR will operate on the highest command step.



CAUTION: Incorrect wiring can damage regulator. Double check all connections.

14. Engage main breaker or disconnect.
15. Set the rotary selector switch to REM. Operate the CCR by remote control, and verify correct current levels are obtained on all brightness steps.
16. Turn the rotary selector switch to OFF
17. De-energize regulator (disengage disconnect switch or main circuit breaker). Remove short-circuit link from output terminals TB-2-1 and TB2-2.
18. Connect the 20 A series lighting circuit to the output terminals and tighten all connections.

Section 4

Operation



WARNING: Contents are static-sensitive. Must be grounded when handling PCB.

1. Introduction

This section provides the operational procedures listed below for the L-828 constant current regulator (CCR) (50-70 kVA/20 A).

- control procedures
- shutdown procedures
- adjustment procedures

2. Control Procedures

This subsection describes the operations of local and remote controls.

Local Control

See Figure 4-1. Refer to Table 4-1. The front panel rotary selector switch is used for regulator local control. The rotary for the 5-step has seven positions. The regulator automatically maintains the output current within $\pm 1\%$ of the nominal value for the brightness position selected.

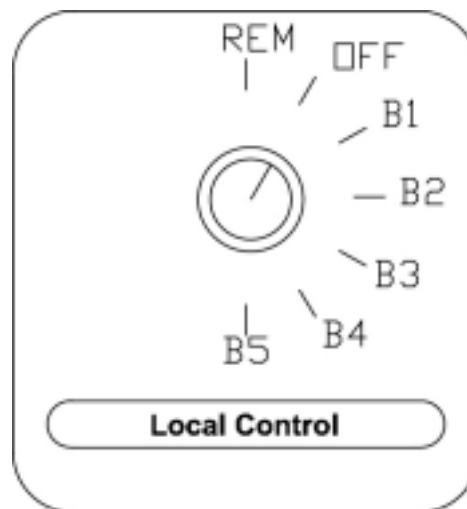

Figure 4-1 Switch (5-Step)

Local Control (*contd.*)

Table 4-1 Output Current from Rotary Switch Positions for Local Control (5-Step/20 A)

If you set to the following...	The result is...
B1	8.5 A current output
B2	10.3 A current output
B3	12.4 A current output
B4	15.8 A current output
B5	20 A current output

Remote Control

See Figure 4-1. Refer to Table 4-4 for instructions on how to set up and use remote control.

Table 4-2 Remote Control

If...	Then...
The rotary switch is set to position REM and remote control wiring is connected to remote control terminal block TB1 on the regulator	The output current of the regulator will correspond to the brightness setting energized by remote 120 Vac.
The rotary switch is set to OFF	Remote control signals will not operate the regulator; that is, turn the regulator on to a particular brightness setting or turn the regulator off.
The rotary switch is set to REM	Remote control of the regulator is possible.
No remote control connections exist on terminal block TB1 (rotary switch is set to REM)	The position REM becomes an additional OFF position; that is, the regulator is de-energized.

3. Shutdown Procedure

See Figure 4-1. To shut down the CCR, set the rotary switch to position OFF.

NOTE: Power to the output terminals is now off, and the regulator cannot be energized by remote control signals. Power is still present on the input power terminals and on the internal control circuitry.

To remove input power, disengage disconnect switch or external circuit breaker.

4. Adjustment Procedures

This subsection provides regulator adjustment procedures.

NOTE: The regulator has been adjusted at the factory to provide the nominal output current levels as given in Table 2-10. If the current level settings need to be adjusted, read the following warning statement before proceeding.



WARNING: Only personnel qualified to work on high voltage systems should attempt to make any adjustments on the constant current regulator.



WARNING: Turn rotary selector switch on the front panel of the regulator to position OFF. Remove input power before servicing control circuitry.



WARNING: Before attempting to service the regulator, remove input power by turning off disconnect switch or main circuit breaker. If the regulator de-energizes suddenly, the output circuit could be interrupted by an overcurrent, open-circuit or undervoltage condition. Turn rotary selector switch to position OFF and disconnect the input power (turn off main circuit breaker or disconnect switch) before inspecting the output circuit. Without this precaution, a dip in the power line may re-energize the regulator, causing an output voltage of thousands of volts to be present. These high voltages can cause serious injury or death.

Output Current Adjustment

To adjust the output current, perform the following procedure:

1. Connect a clamp-on true rms-reading instrument (such as a Fluke 87 multimeter with Y8101A or an AEMC MN 106 or MN 185 current clamp or equivalent) around one of the output current leads.

NOTE: Make sure the meter is set on the AC current scale.

NOTE: Because the output current waveform is not a true sine wave, the ammeter must be of the true-rms type. Field instruments such as clamp-on ammeters and Simpson voltmeters will give erroneously low readings.

2. Energize the regulator locally, and set the rotary selector switch to the maximum brightness position 5.

Output Current Adjustment
(contd.)

- See Figure 4-2. Carefully adjust R40 (1) on the universal regulator controller board until the desired current is measured on the meter.

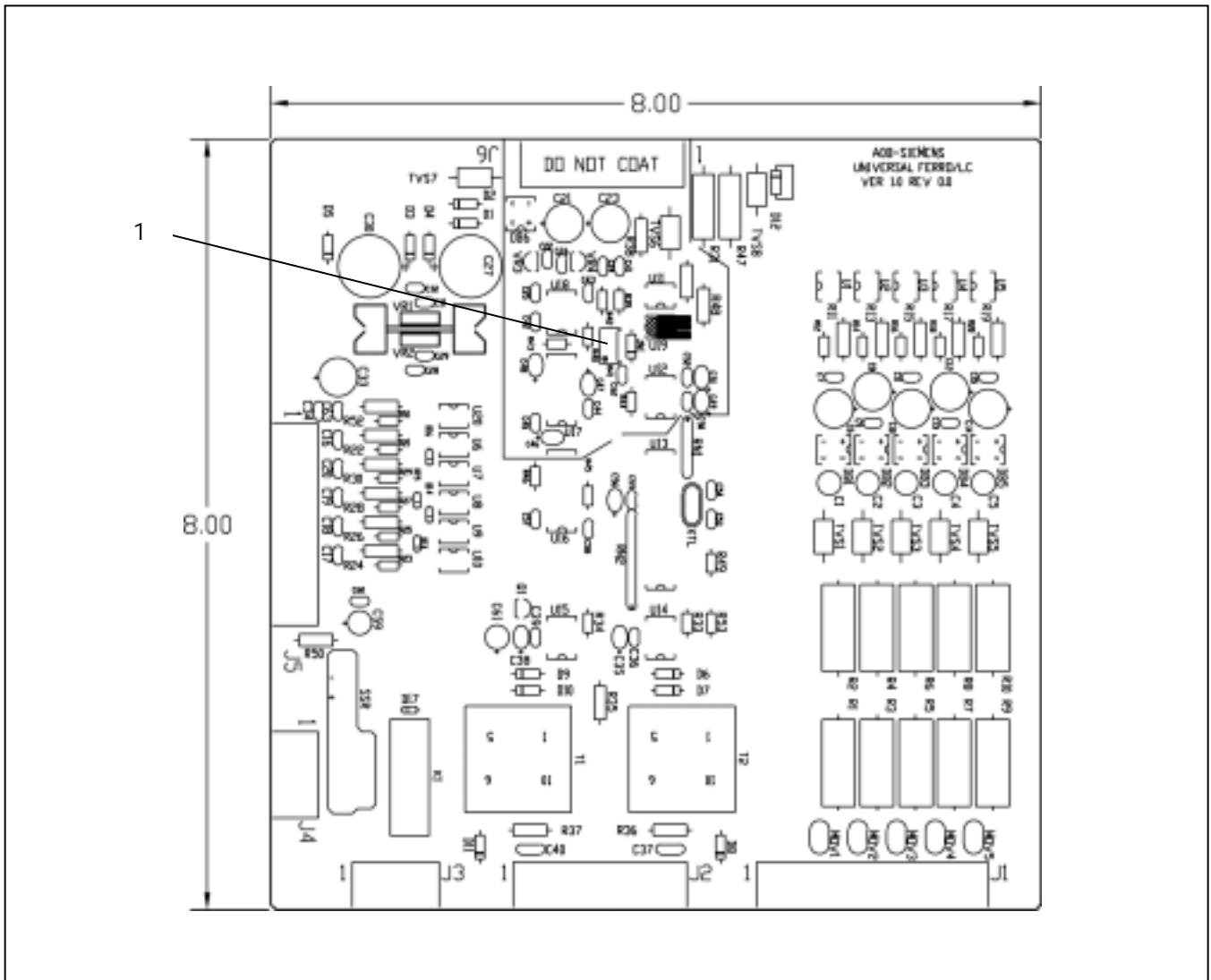

Figure 4-2 R40 on URC Board (1)

Overcurrent Adjustment

No adjustment is provided.

Section 5

Maintenance



WARNING: Only personnel authorized to work on high-voltage equipment should perform maintenance on the regulator.



WARNING: Operate regulator under local control (using the rotary switch) when performing maintenance tasks on the regulator. This will prevent the regulator from accidentally being turned on and causing serious injury or death. De-energize regulator by turning rotary switch to OFF, and remove input power to regulator by turning off disconnect switch or main circuit breaker before opening access door to service regulator.

1. Introduction

This section provides preventive maintenance for L-828 constant current regulators (CCRs) (50-70 kVA/20 A).

2. Maintenance Schedule

To keep the L-828 CCRs operating efficiently, follow a preventive maintenance schedule. Refer to Table 5-1.

Table 5-1 L-828 CCR (50 and 70 kVA/20 A) Maintenance

Interval	Maintenance Task	Action
Daily	Check all control equipment for proper operation.	Check local and remote control (if used) on each brightness step.
Monthly	Check input voltage. Check and record output current on each brightness step.	If input voltage is not within -5% to +10% of the nominal value specified on the nameplate of the regulator, notify power company to correct voltage. Use a true rms-reading instrument. Adjust current levels if out of tolerance. Refer to <i>Adjustment Procedures</i> in the <i>Operation</i> section. Refer to Table 2-10 for the current range for the 5-Step CCRs.

Continued on next page

2. Maintenance Schedule

(contd.)

Table 5-1 L-828 CCR (50 and 70 KVA/20 A) Maintenance

Interval	Maintenance Task	Action
Annually	<p>Check relays, wiring and insulation.</p> <p>Inspect housing for rust spots.</p> <p>Inspect lightning arrestor connections.</p> <p>Perform a short-circuit test.</p> <p>Perform an open-circuit test.</p> <p>Check oil for presence of dirt and water.</p>	<p>Clean dirty or slightly pitted contractor contacts. Use a fine file for surface cleaning. Replace contacts that are excessively burned or pitted.</p> <p>Operate the rotary local control switch to check for proper operation of relays and contactors.</p> <p>Make sure input and output connections are tight and that no damaged wires or burned insulation exists.</p> <p>Clean and touch-up rust spots with paint.</p> <p>Tighten any loose connections. Replace charred or burnt wiring or broken arrestors.</p> <p>Refer to <i>Short-Circuit Test</i> in this section.</p> <p>Refer to <i>Open-Circuit Test</i> in this section.</p> <p>Remove a one-pint sample of oil (replace oil removed from the CCR with an equal amount of new oil) and submit to the laboratory for dielectric test and analysis. If the dielectric strength is low or the oil is dirty, it should be replaced or filtered and dried to restore its dielectric strength. Wash out any sludge deposits on the core and coil assembly and in the tank with clean dry oil.</p>
Unscheduled	Check load on regulator.	At installation and subsequent load changes make sure that the output rms voltage times the output true rms current does not exceed the rated load on the nameplate of the regulator.

Short-Circuit Test



WARNING: Since high open-circuit voltages may result by opening the primary of a series lighting circuit, only personnel authorized to work on high-voltage equipment should be allowed to perform the short-circuit test.

To perform the short-circuit test, perform the following procedure:

1. Remove input power to regulator (turn off disconnect switch or main circuit breaker) and turn rotary switch to OFF.
2. Remove leads from output terminals and bushings. Use AWG 8 or larger wire to short output bushings.
3. Energize the regulator and turn the rotary selector switch to the lowest brightness step (1) and then to the remaining brightness steps. Check the output current on the ammeter at each step. The output current should be within the tolerance given in Table 2-10.
4. If the output current is not within the limits specified in Table 2-10, check the input voltage to the regulator. The supply voltage should be within -5% to $+10\%$ of the nominal input voltage given on the regulator nameplate. Refer to *Adjustment Procedures* in the *Operation* section.
5. Turn off disconnect switch or main circuit breaker to remove input power to regulator.
6. Disconnect the shorting jumper and reconnect output cables.
7. Close input-power disconnect switch or main circuit breaker.

Open-Circuit Test



WARNING: Since high open-circuit voltages may result by opening the primary of a series lighting circuit, only personnel authorized to work on high-voltage equipment should be allowed to perform the open-circuit test.

To perform the open-circuit test, perform the following procedure:

1. Remove input power to regulator (turn off disconnect switch or main circuit breaker) and turn rotary switch to OFF.
2. Disconnect cables from the output terminals and bushings.

Open-Circuit Test *(contd.)*

3. Turn on input power to the regulator.
4. Turn rotary switch to the lowest brightness position (1). The open-circuit protective device should automatically de-energize the regulator in less than 2 seconds.
5. Turn the rotary switch to OFF. The open-circuit protective device should reset.
6. Turn the rotary switch to position 1. The regulator should turn on and then de-energize in less than 2 seconds.
7. If regulator operation is satisfactory, turn the rotary switch to OFF, and turn off disconnect switch or main circuit breaker before reconnecting the load.
8. After the load has been reconnected, turn on input power to the regulator.

Oil Removal and Replacement

Remove input power to the regulator by turning off the disconnect switch or main circuit breaker before attempting to remove oil.

NOTE: The oil fill valve is located on the top rear of the tank, and directly below is the oil drain valve. Always use clean dry oil (Shell Diala AX or Texaco #55). No water should be present. Oil does not contain any PCBs.

To change the oil in the tank, perform the following procedure:

1. Open the oil fill valve at the top of the tank, and drain the old oil from the tank through the oil drain valve.
2. Wash out any sludge deposits in the tank using clean dry oil.
3. Refill the tank by using a gear pump to pump the oil into the tank through the coil drain valve on the bottom of the tank, and open the oil fill valve to allow air in the tank to escape.

NOTE: Use a gear pump to avoid pumping air into the tank with the oil.

NOTE: Fill the tank initially to a level slightly above the midpoint of the oil gauge on the tank (slightly above the middle of the two reference markers on the oil gauge).

4. Wait approximately two hours for any air present in the oil to escape and if necessary, pump additional oil into the tank to bring the oil level to the midpoint of the gauge.

Oil Removal and Replacement *(contd.)*

5. Close the oil fill valve, drain the valve, and remove the pump.
6. Wait at least two additional hours, and check the oil level to make sure it hasn't changed. If the level has dropped and the ambient temperature has not changed, add oil through the oil fill valve to bring the level back to the midpoint before turning the regulator on.

NOTE: The oil level on the gauge will depend on the temperature of the oil. When the regulator is turned on, the oil will be heated by the regulator, causing the level to rise on the gauge.

NOTE: Approximately 160 gallons (605.7 liters) of oil are required for the 50 kVA CCR.

Section 6

Troubleshooting



WARNING: Allow only qualified personnel to perform the following tasks. Observe and follow the safety instructions in this document and all other related documentation.



WARNING: De-energize regulator by turning rotary switch S1 to OFF, and remove input power to regulator by turning off disconnect switch or main circuit breaker. Discharge capacitors and ground output terminals bushings by using a grounding rod prior to touching any parts.



WARNING: If regulator de-energizes suddenly, the output circuit could be interrupted by an overcurrent, open-circuit, or undervoltage condition. Before inspecting the output circuit, place the rotary selector switch in the OFF position and turn off disconnect switch or main circuit breaker. Without this precaution, a dip in the power line may reset the fault and re-energize the regulator, resulting in an output voltage of thousands of volts which can cause serious injury or death.



CONTENTS
STATIC-SENSITIVE
MUST BE GROUNDED
WHEN HANDLING PCB

WARNING: Contents are static-sensitive. Must be grounded when handling PCB.



CAUTION: Short the output terminals/bushings before switching the regulator on. The wire should be AWG 8 or larger.

1. Introduction

This section provides the following troubleshooting information for the ferroresonant L-828 CCR (50/70 kVA/20 A): preliminary troubleshooting check list and troubleshooting procedures.

2. Preliminary Troubleshooting

The following is a check list of initial steps to perform.

- Visually examine all areas of the CCR. Do burnt or loose connections/parts exist?
- Is the input voltage present and within +10 to -5% of nominal?
- Check all the fuses.
- Are the wire harness connectors to the control board fully seated?
- Have the PCBs been adjusted in accordance with the instruction manual?
- If the CCR works in local but not Remote, check the voltage on the Remote control lines.
- Can the CCR be re-energized by turning the rotary switch from OFF to Step B1?
- Short the output of the CCR with an AWG 8 wire, and turn on the CCR. If the regulator operates normally, the problem is probably load related.
- If the CCR turns on and then shuts off after a few seconds and the ammeter has a high current reading, the problem is overcurrent. Check all connections to the regulator control board and the SCR.
- Adjust the output current accordingly. If the output current is not adjustable, replace the control board and SCR protection network. If the regulator still fails to regulate, replace the SCRs.

3. Troubleshooting Fuses

This subsection provides information for troubleshooting fuses.

Input Power Fuses F1 and F2

Refer to Table 6-1 for amp rating as a function of input voltage and CCR kVA rating for input power fuses F1 and F2.

NOTE: No input power fuses exist on the 2400 Vac regulators.

Table 6-1 CCR Input Voltage and CCR kVA Rating for Input Power Fuses F1 and F2

CCR Input Voltage	CCR kVA Rating	
	50 kVA	70 kVA
480 Vac	125 A	200 A
2400 Vac	Not applicable	Not applicable

**Step-Up/Down Transformer
T3 Fuses F3 and F4**

Refer to Table 6-2. Fuses F3 and F4 protect transformer T3, which supplies 240 Vac to contractor coil and universal regulator power supply transformer T4.

NOTE: On 2400 Vac CCRs, fuses F3 and F4 are replaced by fuses F1 and F2 with a rating of 0.63 A, 4800 V.

Table 6-2 Transformer T3 Fuses F3 and F4 Ratings

CCR Input Voltage	Fuse F3 and F4 Rating	Fuse F1 (2400 Vac) Rating
480 Vac	3 amps	Not applicable
2400 Vac	Not applicable	0.63 A, 4800 V

**Universal Regulator Power
Supply Transformer Fuses
F5 and F6**

Universal regulator power supply transformer fuses F5 and F6 protect T4 and are ½ amp, 250 V.

F7 Transformer Fuse

This ½ amp, 250 V fuse protects transformer T6 or T3, depending on input voltage. This 120 V source to CCR power is used only on the 208/220 and 2400 Vac regulators.

F9 Transformer Fuse

This ½ amp, 250 V fuse protects the regulator control board and other optional devices.

**4. General Troubleshooting
Procedures**

This subsection provides general troubleshooting procedures.

Problem	Possible Cause	Corrective Action
1. Regulator not turning on	Main power supply off	Verify presence of input voltage.
	Switched off due to overcurrent	Switch regulator off in local. Wait for 2 seconds and check to see if the regulator now operates correctly.
	Incorrect external wiring	If the regulator works correctly in local but not in Remote, check the Remote control signals.
	Blown fuse	Replace any blown fuse. Check the input supply voltage and make sure that it is between -5% and +10% of the nominal value listed on the CCR nameplate.
	Defective PCB	Replace PCB.

Continued on next page

4. General Troubleshooting Procedures *(contd.)*

Problem	Possible Cause	Corrective Action
2. Regulator turns on but de-energizes suddenly	Output circuit interrupted Defective printed circuit board Overcurrent condition	Short-circuit to the regulator output with #8 AWG wire or larger. Turn the regulator on. If the regulator works correctly, repair the lighting circuit. Follow all safety precautions in this manual. Replace regulator controller. Verify SCR ignition by replacing the PCB or SCR protection network, or viewing SCR current on a scope. Check SCRs and wiring. Replace SCR.
3. Output Current always 6.6 A/20 A or more	Universal regulator controller not calibrated Overcurrent condition	With regulator set on Step (B5), adjust R40 until a current reading of 20 A is measured. Check remaining steps to verify the values from Table 2-10. Refer to problem #2 in this table, <i>Regulator turns on but de-energizes suddenly.</i>
4. Output Current always 8.5 or less on 20 A	Defective control board SCRs always conducting Defective resonant circuit (transformer or capacitor) CCR overload	If problem exists in Remote and local control, replace universal regulator controller. If possible, check the SCR current with a scope. Otherwise, verify SCR ignition by replacing PCB. Check SCRs and wiring for shorts in SCR circuitry. Replace SCR protective network PCB. Replace SCR. Visually inspect capacitors for damaged housing or wire connections. Visually inspect transformer for damaged coils, connections, and/or wiring. Faulty capacitors will exhibit a bulging case. Remove section of load.
		Continued on next page

4. General Troubleshooting Procedures *(contd.)*

Problem	Possible Cause	Corrective Action
5. More than 2 seconds required for CCR to de-energize on open-circuit load	Faulty overcurrent protection	Replace URC PCB.
6. Short lamp life and/or high output current reading on panel ammeter	Incorrect output current adjustment	Refer to <i>Output Current Adjustment</i> in the <i>Operation</i> section.
	Faulty overcurrent protection	Replace URC PCB.
7. Regulator not indicating proper current	Incorrect output current adjustment	Refer to <i>Output Current Adjustment</i> in the <i>Operation</i> section.
	Defective controller	Replace universal regulator controller.
8. Regulator operates by local rotary control switch, but not by Remote control	Rotary switch not set to REM	Set the rotary switch to REM.
	Blown fuse	Check fuse F9. On 2400 Vac regulators, check fuse F7.
	Loose or broken Remote control wires	Check connections on Remote terminal block TB1. Use an AC voltmeter (300 Vac scale) to verify correct signals are received at the CCR.
	Incorrect wire connections	Refer to Table 3-3.
9. Ammeter on CCR oscillates and loud growling noise occurs	SCR drive not working properly	Check connections at SCR module. Replace URC PCB.
10. Output current not able to be adjusted up to 20 A	Regulator load too large	Either reduce the load or replace the regulator with a larger kVA CCR. NOTE: This problem can also be verified by shorting the output of the CCR and verifying output current can be adjusted correctly in each step.

Section 7

Parts

1. Introduction

To order parts, call Siemens Airfield Solutions Customer Service or your local representative. Use this four-column parts list, and the accompanying illustration, to describe and locate parts correctly.

2. Using the Illustrated Parts List

This subsection describes how to use the illustrated parts list covered later in this section. It does not provide the actual parts list.

The Part Number column gives the Siemens Airfield Solutions part number.

The Description column gives the part name, as well as its dimensions and other characteristics when appropriate. Indentions show the relationships between assemblies, subassemblies, and parts.

Part Number	Description	Quantity	Note
XXXXXXXX	Assembly	1	A
XXXXXXXX	Part	1	
XXXXXXXX	Part or Assembly		
XXXXXXXX	Assembly	1	
NOTE A			

The Quantity column contains the quantity required per unit, assembly, or subassembly. The code AR (As Required) is used if the part number is a bulk item ordered in quantities or if the quantity per assembly depends on the product version or model.

The Note column contains letters that refer to notes at the end of each parts list. Notes contain special ordering or product/part version information.

3. L-828 CCR (50 and 70 kVA/20 A) Part Numbering System

Refer to Table 7-1 for the ferroresonant L-828 CCR (50 and 70kVA/20 A) part numbers.

Table 7-1 L-828 CCR (50 and 70 kVA/20 A) Part Numbers

kVA Rating	480 V	2400V
50 kVA	44D1364-3U	44D1365-3U
70 kVA	44D1367-3U	44D1368-3U

4. L-828 CCR General Assembly (50/70 kVA/480 and 2400 Vac/20 A) Parts List

This subsection provides part numbers for the L-828 ferroresonant CCR (50 kVA/480 V/20 A and 70 kVA/480 and 2400 Vac/20 A). See Figure 8-1 in the *Wiring Schematics* section.

Part Number	Description	Quantity Used				Schematic Reference	Note
		50 kW 480 V	70 kW 480 V	50 kW 2400 V	70 kW 2400 V		
20A0019	Capacitor	60	80	50	70	C1, C2...	
28A0028	Dual SCR module assembly 500A-1600V	1	1	1	1	SCR block	
32A0024	Surge arrester 6 kV	2	2	2	2	VR1, VR2	
32A0032	Varistor, V271DA40	0	0	2	2	K2	
35A0150	SD transformer 50 and 70 kVA/480 V	1	1	0	0	T3	
35A0308	Current transformer, 20A/6.6 A, 70 kVA, 480/2400 V	1	1	1	1	T2	
35A0277	Dual transformer, 115/230 V	0	0	1	1	T6	
35A0493	Transformer, current sense, 6.6 A TO 66 mA	1	1	1	1	T5	
35A0496	Transformer, 115/230 TO 12/24 V 25 VA	1	1	1	1	T4	
35B0219	240-120 transformer	0	0	1	1	T8	

Continued on next page

**4. L-828 CCR General
Assembly (50/70 kVA/480
and 2400 Vac/20 A) Parts
List (contd.)**

Part Number	Description	Quantity Used				Schematic Reference	Note
		50 kW 480 V	70 kW 480 V	50 kW 2400 V	70 kW 2400 V		
35C0127	2400-120 transformer	0	0	1	1	T3	
35C0190	Power transformer, 50 kVA/ 480 V/20 A only	1	0	0	0	T1	
35C0191	Power transformer, 50 A, 2400 V/20 A	0	1	0	0	T1	
35C0193	Power transformer, 70 kVA, 480 V/20 A	0	1	0	0	T1	
35C0194	Power transformer, 70 kVA, 2400 V/20 A	0	0	0	1	T1	
44A6166	Rotary switch assembly	1	1	1	1	Not applicable	
44A5936	URC regulator card	1	1	1	1	URC/PCB	
47A0061	Fuse block	4	4	4	4	F5, F6, F8, F9	
47A0106	Fuse 125 A, 600 V	2	0	0	0	F1, F2	
47A0119	Fuse, ½ A, 250 V, SLO-BLO	4	4	4	4	F5, F6, F8, F9	
47A0141	Fuse, 200A, 600 V, 70 kVA, 20 A, 480/2400 V	0	2	0	0	F1, F2	
47A0187	Fuse, 3 A, 500 V	2	2	0	0	F3, F4	
49A0084	Fuse holder	1	1	0	0	F3, F4	
49A0097	Fuseblock, 101-200A, 600 V (50 and 70 kVA/480 V)	2	2	0	0	F1, F2	
52A0098	Ammeter, true RMS 0-25	1	1	1	1	Not applicable	
53A0192	Contactor, 3P, 150 A, 240 V coil	1	0	0	0	K2	
53A0247	Contactor, 1P, 33 A, 3500 Vac	0	0	2	2	K2	

Continued on next page

4. L-828 CCR General Assembly (50/70 kVA/480 and 2400 Vac/20 A) Parts List (contd.)

Part Number	Description	Quantity Used				Schematic Reference	Note
		50 kW 480 V	70 kW 480 V	50 kW 2400 V	70 kW 2400 V		
53A0333	Contactora, 3P 150 A, 240 V coil	0	1	0	0	K2	
54A0007	Thermostat, 240 Vac/5A	0	0	1	1	K2	
64A0309	Eyebolt, 1 and ¼-7, 6400 lb	4	4	4	4	Not applicable	
67A0024	Oil transformer	165	160	165	160	Not applicable	A
77A0137	Level liquid, ½-in., NPT, 5-in., centers	1	1	1	1	Not applicable	
85A0054	Heater strip, 150 W, 240 V	0	0	1	1	K2	
NOTE A: Quantity is in gallons.							

5. Recommended Spare Parts

This subsection provides recommended spare parts.

Description	Quantity	Schematic Referenced
Box of each type of fuse	Box	F1 through F9
SCR	2	SCR
URC board	1	URC I PCB
contactor	1	K2
Feedback c/t	1	T5
Set of output lightning arrestors	1 set	VR2-5
Lugs	1 set	Miscellaneous
Terminals	1 set	Miscellaneous
Rotary control switch	1 set	Not applicable
Ribbon cable for RCS	1	Not applicable

Section 8

Wiring Schematics

1. Introduction

This section provides ferroresonant L-828 constant current regulator (CCR) (50 and 70 kVA/20 A) with universal regulator controller (URC) wiring schematics.

2. Wiring Schematics

See Figure 8-1 for the L-828 CCR (50 and 70 kVA/20 A) internal wiring schematic.

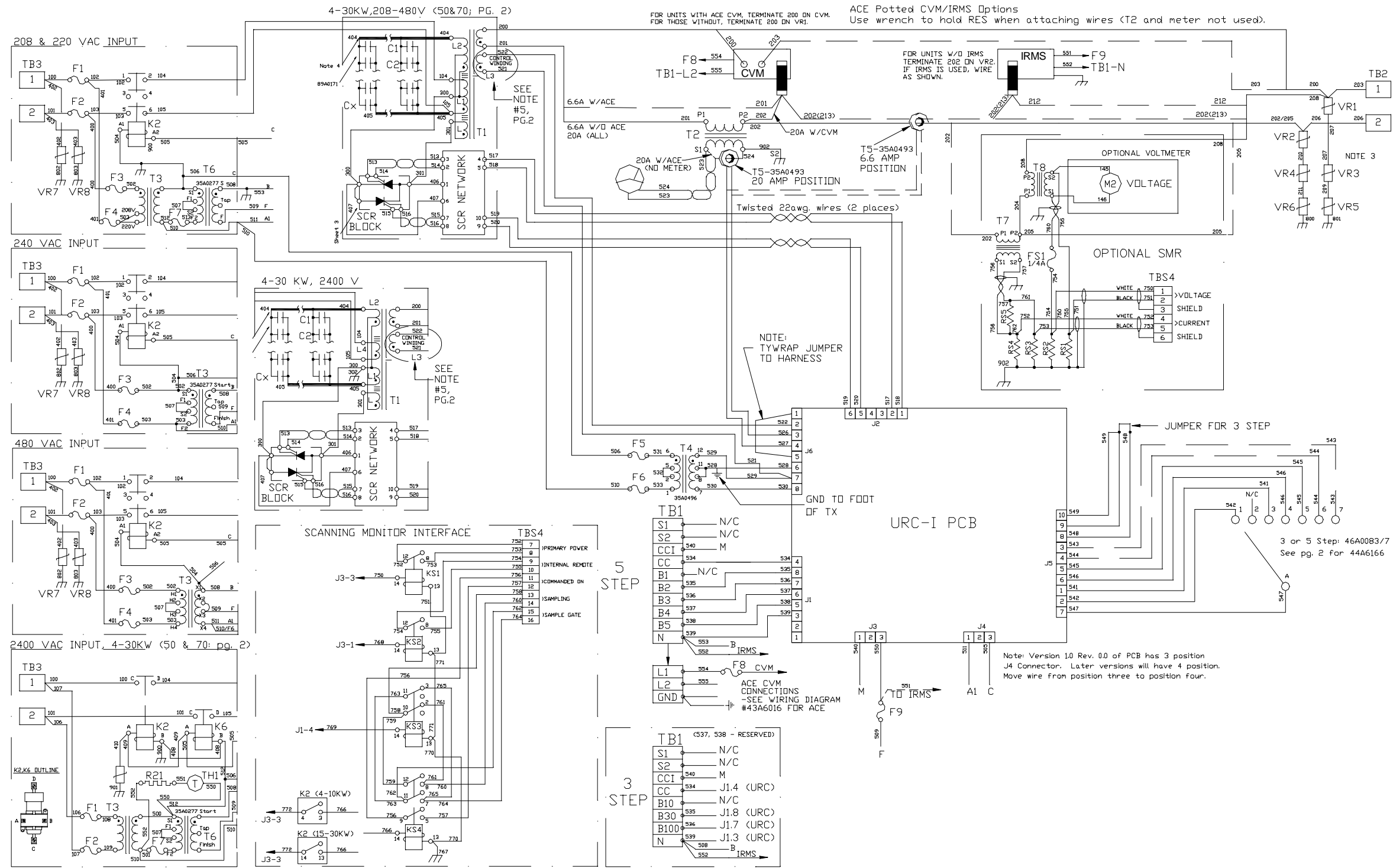

Figure 8-1 L-828 CCR with URC (50 and 70 KVA) Internal Wiring Schematic (Part 1 of 2)

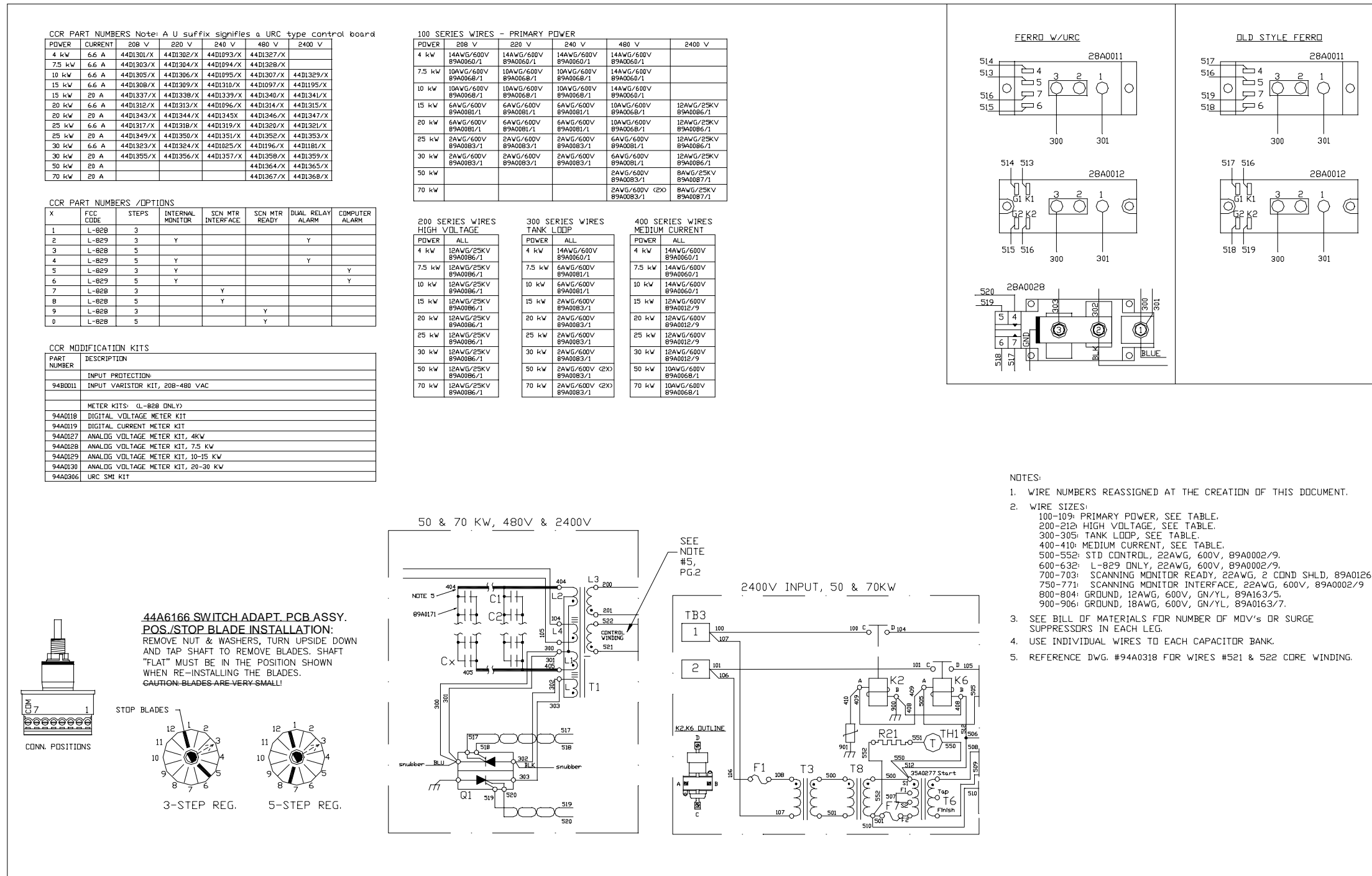

Figure 8-1 L-828 CCR with URC (50 and 70 kVA) Internal Wiring Schematic (Part 2 of 2)